

Series CHE Compact Hydraulic Cylinders

Catalog HY04-AC1137-2/NA
January, 2007



ATLAS CYLINDERS

Cylinder Features

**Compact Hydraulic Cylinders
Series CHE**

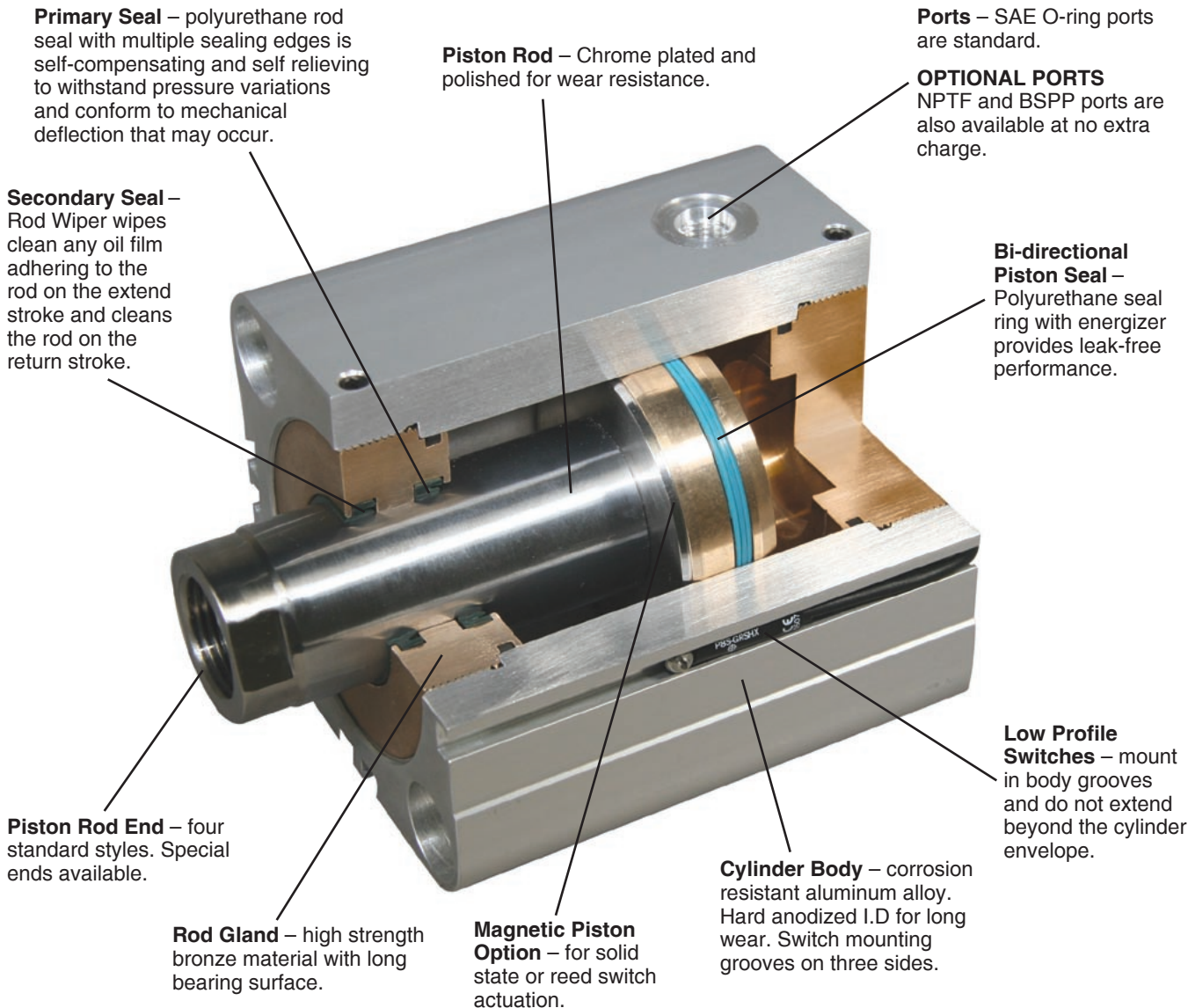

CHE Compact Hydraulic Cylinders...

Require less mounting space than conventional tie rod cylinders.

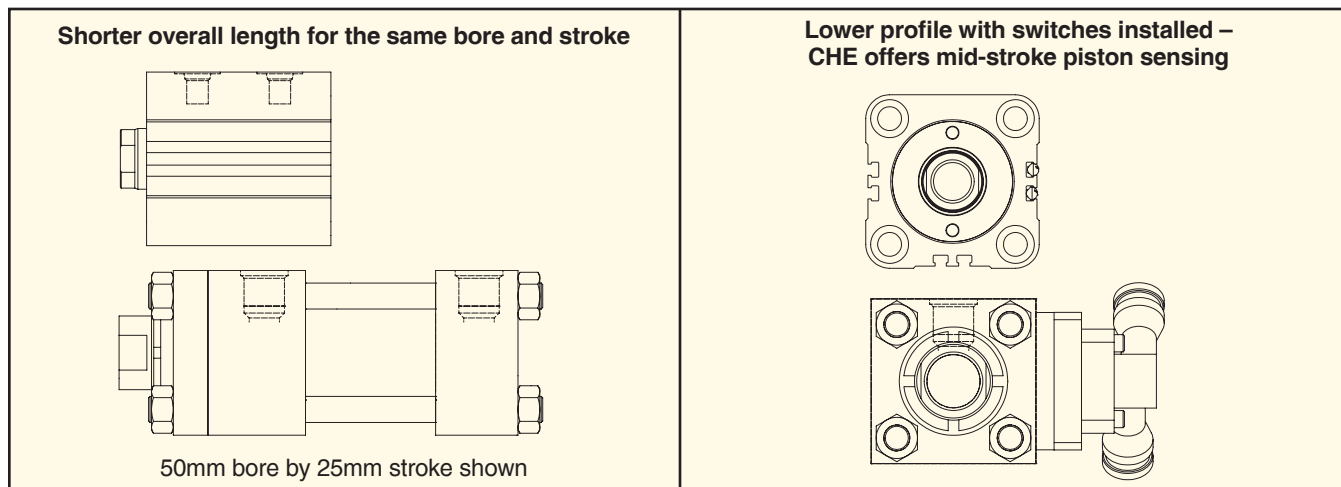

Table of Contents	Page No.
Cylinder Features	IFC
Theoretical Push and Pull Forces, Pressure Rating	2
Cylinder Weights	2
Standard Specifications	3
Model Numbers – How to Develop and Decode Them	3
T Mount – Single Rod End.....	4
T Mount – Double Rod End.....	5
TN & TR Mount – Single Rod End	6
TN Mount – Double Rod End	7
J & H Mount – Single Rod End.....	8
J Mount – Double Rod End	9
CA Mount – Single Rod End.....	10
CA Mount – Double Rod End	11
Solid State Switches	13
Reed Switches	14
Switch Mounting, End-of-Stroke Switch Location.....	15
Mounting Bolt Size & Torque Recommendations	16
Bolt Kits for T, TN & TR Mounts	16
Parts Identification, Minimum Rod Extension	17
Seal Kits, Gland & Cap Spanner Holes	18
Cylinder Safety Guide	19-20
Offer of Sale.....	IBC

 **Warning**

FAILURE OR IMPROPER SELECTION OR IMPROPER USE OF THE PRODUCTS AND/OR SYSTEMS DESCRIBED HEREIN OR RELATED ITEMS CAN CAUSE DEATH, PERSONAL INJURY AND PROPERTY DAMAGE.

This document and other information from The Company, its subsidiaries and authorized distributors provide product and/or system options for further investigation by users having technical expertise. It is important that you analyze all aspects of your application, including consequences of any failure and review the information concerning the product or system in the current product catalog. Due to the variety of operating conditions and applications for these products or systems, the user, through its own analysis and testing, is solely responsible for making the final selection of the products and systems and assuring that all performance, safety and warning requirements of the application are met.

The product described herein, including without limitation, product features, specifications, designs, availability and pricing, are subject to change by The Company and its subsidiaries at any time without notice.

Offer of Sale

The items described in this document are hereby offered for sale by The Company, its subsidiaries or its authorized distributors. This offer and its acceptance are governed by provisions stated on a [separate page of the document entitled 'Offer of Sale'](#).

Theoretical Push and Pull Forces

The cylinder output forces are derived from the formula:

$$F = \frac{P \times A}{10000}$$

Where F = Force in kN.

P = Pressure at the cylinder in bar.

A = Effective area of cylinder piston in square mm.

To determine the bore size for the application take the following steps.

1. Select the Operating Pressure column closest to that desired.

2. In the same column, identify the force required to move the load (always rounding up). If the piston rod is in compression use the 'Push' row and if the piston rod is in tension use the 'Pull' row.

3. In the row to the left is the bore required.

If the cylinder envelope dimensions are too large for the application, increase the operating pressure to the maximum pressure in the table below, if possible, and repeat steps 1 - 3.

Push and Pull Force in kN

Bore Ø	Rod Ø	Operating Direction	Piston Area (mm²)	Operating Pressure (Bar)						
				20	40	60	80	100	120	140
20	12	Push	314	0.63	1.26	1.88	2.51	3.14	3.77	4.40
		Pull	201	0.40	0.80	1.21	1.61	2.01	2.41	2.81
25	14	Push	491	0.98	1.96	2.95	3.93	4.91	5.89	6.87
		Pull	337	0.67	1.35	2.02	2.70	3.37	4.04	4.72
32	18	Push	804	1.61	3.22	4.83	6.43	8.04	9.65	11.3
		Pull	550	1.10	2.20	3.30	4.40	5.50	6.60	7.70
40	22	Push	1,257	2.51	5.03	7.54	10.1	12.6	15.1	17.6
		Pull	877	1.75	3.51	5.26	7.01	8.77	10.5	12.3
50	28	Push	1,963	3.93	7.85	11.8	15.7	19.6	23.6	-
		Pull	1,348	2.70	5.39	8.09	10.8	13.5	16.2	-
63	36	Push	3,117	6.23	12.5	18.7	24.9	31.2	-	-
		Pull	2,099	4.20	8.40	12.6	16.8	21.0	-	-
80	45	Push	5,027	10.1	20.1	30.2	40.2	50.3	-	-
		Pull	3,436	6.87	13.7	20.6	27.5	34.4	-	-
100	56	Push	7,854	15.7	31.4	47.1	62.8	78.5	-	-
		Pull	5,391	10.8	21.6	32.3	43.1	53.9	-	-

**Series CHE
Pressure Rating**

Bore Ø	Maximum Working Pressure in bar
20	140
25	140
32	140
40	140
50	120
63	100
80	100
100	100

Equivalents

1 kN = 224.81 pounds force

1 bar = 14.50 psi

1 mm = .03937 inch

1 mm² = .00155 inch²

Cylinder Weights

To determine the weight of a Series CHE cylinder, first select the proper basic zero stroke weight for the mounting required, and then calculate the weight of the

cylinder stroke and add the result to the basic weight. For extra rod extension, use piston rod weights per mm in Table C.

Table A Single Rod End CHE Cylinder Weights in kg.

Bore Ø	Rod Ø	Single Rod Cylinders					
		Basic Weight at Zero Stroke		Per mm Stroke	Basic Weight at Zero Stroke		Per mm Stroke
		T	TN, TR		J, H	CA	
20	12	0.27	0.29	0.004	0.54	0.51	0.005
25	14	0.39	0.41	0.005	0.77	0.74	0.006
32	18	0.73	0.76	0.009	1.26	1.40	0.009
40	22	1.09	1.13	0.011	2.04	2.18	0.013
50	28	1.68	1.74	0.015	3.28	3.43	0.017
63	36	2.85	2.96	0.021	4.88	5.68	0.025
80	45	4.38	4.43	0.031	7.77	8.76	0.036
100	56	8.33	8.45	0.045	14.94	15.78	0.051

Table C Piston rod weights in kg.

Rod Ø	Piston Rod Weight Per mm
12	0.0009
14	0.0012
18	0.0020
22	0.0030
28	0.0048
36	0.0080
45	0.0125
56	0.0193

Equivalent

1 kg = 2.2046 pounds

Table B Double Rod End CHE Cylinder Weights in kg.

Bore Ø	Rod Ø	Double Rod Cylinders					
		Basic Weight at Zero Stroke		Per mm Stroke	Basic Weight at Zero Stroke		Per mm Stroke
		T	TN		J	CA	
20	12	0.29	0.31	0.005	0.57	0.53	0.006
25	14	0.43	0.44	0.006	0.80	0.78	0.007
32	18	0.79	0.82	0.011	1.32	1.46	0.011
40	22	1.19	1.23	0.014	2.14	2.27	0.016
50	28	1.86	1.93	0.020	3.46	3.61	0.022
63	36	3.21	3.32	0.029	5.24	6.04	0.033
80	45	5.07	5.13	0.044	8.47	9.46	0.049
100	56	9.79	9.91	0.064	16.4	17.24	0.070

Model Code & Standard Specifications

Model Ordering Code for CHE

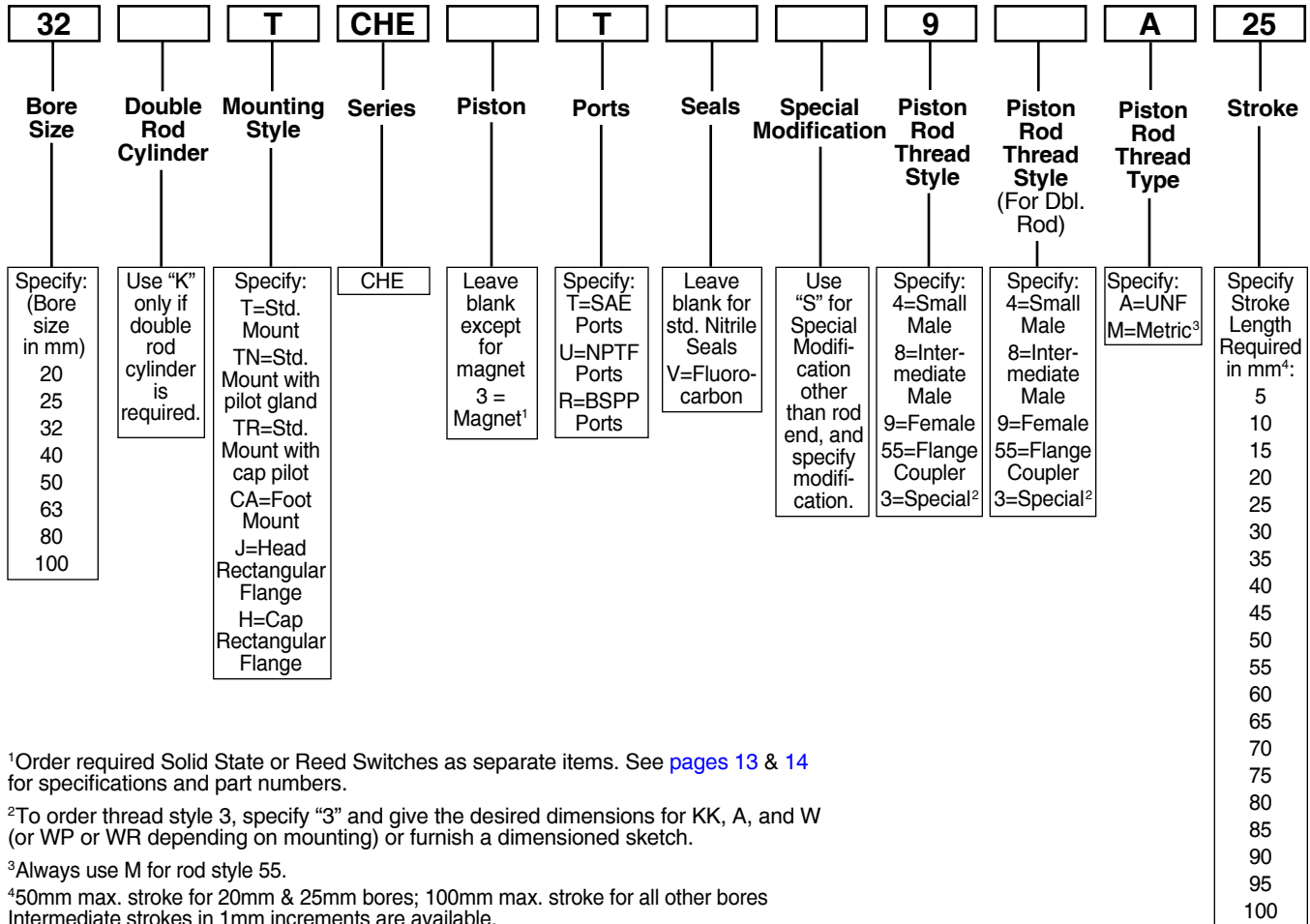

¹Order required Solid State or Reed Switches as separate items. See pages 13 & 14 for specifications and part numbers.

²To order thread style 3, specify "3" and give the desired dimensions for KK, A, and W (or WP or WR depending on mounting) or furnish a dimensioned sketch.

³Always use M for rod style 55.

⁴50mm max. stroke for 20mm & 25mm bores; 100mm max. stroke for all other bores
Intermediate strokes in 1mm increments are available.

Standard Specifications

- 6 Standard mounting styles
- Bore sizes – 20mm to 100mm
- Working pressure up to 140 bar (depending on bore size)
- Piston Rod Diameter – 12mm to 56mm
- Single and double rod construction available
- Temperature range – -23°C to +121°C (depending on seal class)
- Strokes – to 50mm for 20mm & 25mm bores; to 100mm for 32mm & larger bores
- Reference ISO 16656: 2004

Seal Classes	Typical Fluids	Temperature Range
1 – Standard Nitrile & Polyurethane	Hydraulic Oil, MIL-H-5606 Oil	-23°C (-10°F) to +74°C (+165°F)
5 – Optional (At extra cost) Fluorocarbon Seals	High Temperature	-23°C (-10°F) to +121°C (+250°F) Class 5 seals may be operated up to +204°C (+400°F) with reduced service life

Note: Class 5 seals are not suitable for use with Skydrol fluid, but can be used with hydraulic oil if desired.

T Mount – Single Rod End

T Mount – Single Rod End – 20mm to 100mm Bore Size

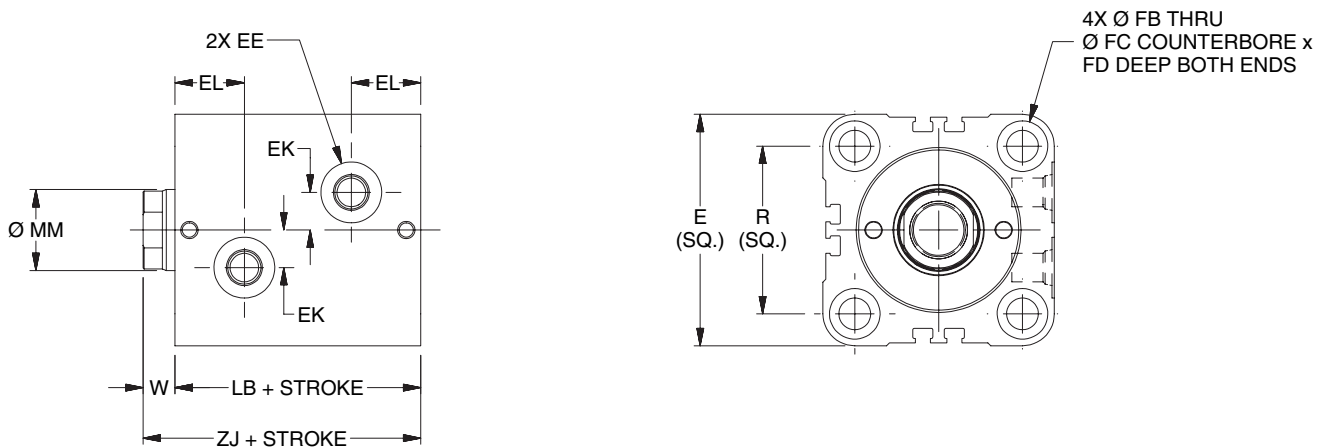

T Mount Single Rod End – Envelope and Mounting Dimensions

Bore Ø	E	EE			EK	EL	FB	FC	FD	LB	R	W	ZJ
		SAE	NPTF	BSP									
20	43*	#2	1/8	G-1/8	6	16.5	5.5	9.5	5.4	43	30	8	51
25	49	#2	1/8	G-1/8	8	17.5	5.5	9.5	5.4	45	36	8	53
32	62	#4	1/4	G-1/4	11	20.5	7	11	6.5	51	47	10	61
40	70	#4	1/4	G-1/4	12	21	9	14	8.6	55	52	10	65
50	80	#4	1/4	G-1/4	14	23.5	11	17.5	10.8	60	58	11	71
63	94	#4	1/4	G-1/4	17	26	13.5	20	13	67	69	13	80
80	114	#6	3/8	G-3/8	20	29.5	16	23	15.2	78	86	17	95
100	138	#6	3/8	G-3/8	25	35	18	26	17.5	96	106	26	122

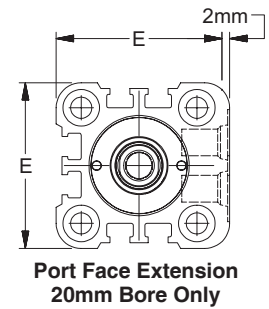

*Port face on 20mm bore is extended 2mm. See port face extension drawing.

T Mount Single Rod End – Rod Dimensions

Bore Ø	MM Rod Ø	Rod End														Rod Extension Dimensions		
		Style 9M		Style 4M		Style 9A		Style 4A		Style 8A		Style 55M				C	D	NA
		KK	A	KK	A	KK	A	KK	A	CC	A	AD	AE	AF	AM			
20	12	M8x1.25	10	M8x1	14	5/16-24	10	5/16-24	14	3/8-24	16	8	3	6	11	6	10	11
25	14	M10x1.5	12	M10x1.25	16	3/8-24	12	3/8-24	16	1/2-20	18	12	4	8	13	6	12	13
32	18	M12x1.75	15	M12x1.25	18	7/16-20	15	7/16-20	18	9/16-18	25	16	6	10	16	8	15	17
40	22	M16x2	20	M16x1.5	22	5/8-18	20	5/8-18	22	3/4-16	30	20	8	12	20	8	19	21
50	28	M20x2.5	24	M20x1.5	28	3/4-16	24	3/4-16	28	7/8-14	35	24	10	16	25	9	24	27
63	36	M27x3	30	M27x2	36	1-14	30	1-14	36	1 1/4-12	45	28	12	22	33	11	32	35
80	45	M33x3.5	35	M33x2	45	1 1/4-12	35	1 1/4-12	45	1 1/2-12	56	34	14	28	41	13	39	43
100	56	M42x4.5	45	M42x2	56	1 1/2-12	45	1 1/2-12	56	1 3/4-12	70	42	16	35	52	22	48	54

Rod End Dimensions

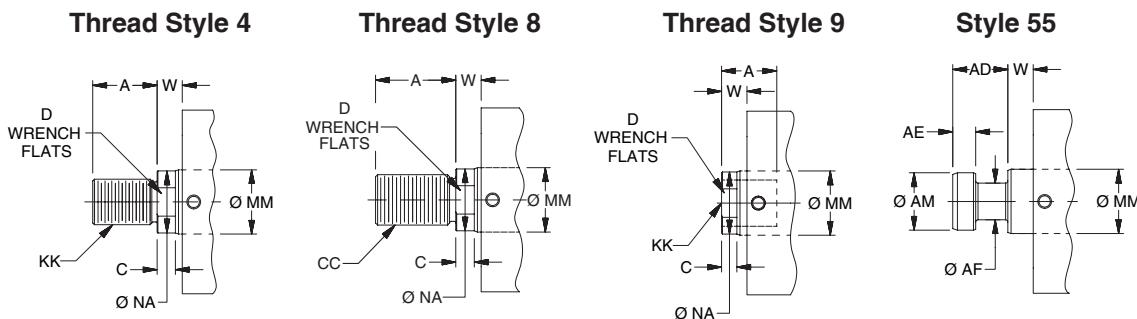

“Special” Thread Style 3
Special thread, extension, rod eye, blank, etc. are also available. To order, specify “Style 3” and give desired dimensions for KK, A, & W. If otherwise special furnish dimensional sketch.

T Mount – Double Rod End

T Mount – Double Rod End – 20mm to 100mm Bore Size

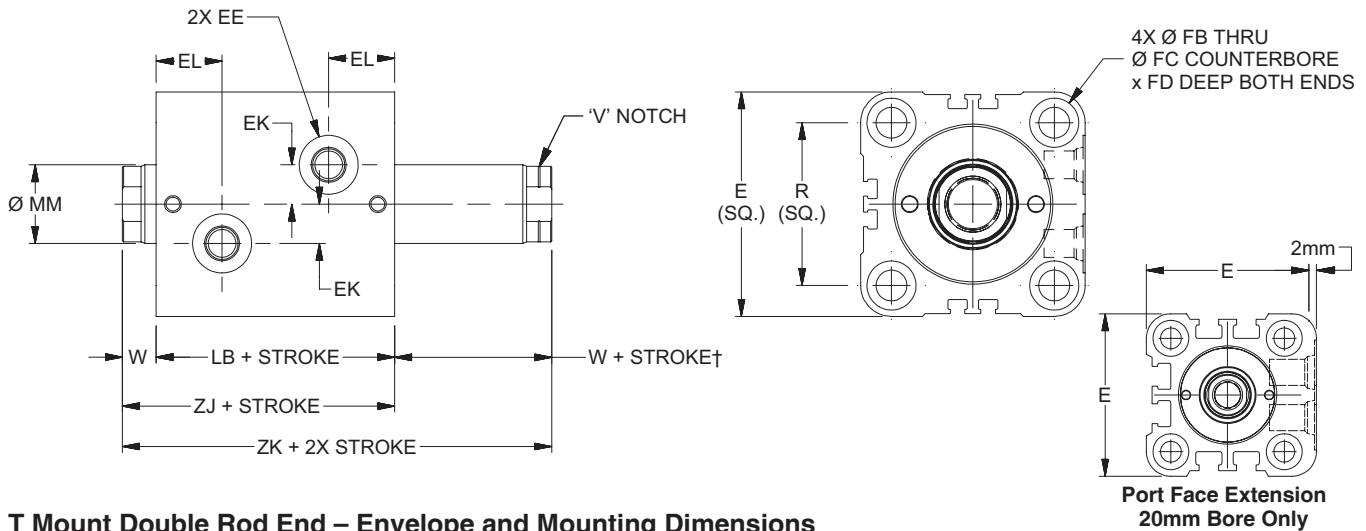

T Mount Double Rod End – Envelope and Mounting Dimensions

Bore Ø	E	EE			EK	EL	FB	FC	FD	LB	R	W†	ZJ	ZK
		SAE	NPTF	BSP										
20	43*	#2	1/8	G-1/8	6	16.5	5.5	9.5	5.4	43	30	8	51	59
25	49	#2	1/8	G-1/8	8	17.5	5.5	9.5	5.4	45	36	8	53	61
32	62	#4	1/4	G-1/4	11	20.5	7	11	6.5	51	47	10	61	71
40	70	#4	1/4	G-1/4	12	21	9	14	8.6	55	52	10	65	75
50	80	#4	1/4	G-1/4	14	23.5	11	17.5	10.8	60	58	11	71	82
63	94	#4	1/4	G-1/4	17	26	13.5	20	13	67	69	13	80	93
80	114	#6	3/8	G-3/8	20	29.5	16	23	15.2	78	86	17	95	112
100	138	#6	3/8	G-3/8	25	35	18	26	17.5	96	106	26	122	148

*Port face on 20mm bore is extended 2mm. See port face extension drawing.

T Mount Double Rod End – Rod Dimensions

Bore Ø	MM Rod Ø	Rod End														Rod Extension Dimensions		
		Style 9M†		Style 4M		Style 9A†		Style 4A		Style 8A		Style 55M						
		KK	A	KK	A	KK	A	KK	A	CC	A	AD	AE	AF	AM	C	D	NA
20	12	M8x1.25	10	M8x1	14	5/16-24	10	5/16-24	14	3/8-24	16	8	3	6	11	6	10	11
25	14	M10x1.5	12	M10x1.25	16	3/8-24	12	3/8-24	16	1/2-20	18	12	4	8	13	6	12	13
32	18	M12x1.75	15	M12x1.25	18	7/16-20	15	7/16-20	18	9/16-18	25	16	6	10	16	8	15	17
40	22	M16x2	20	M16x1.5	22	5/8-18	20	5/8-18	22	3/4-16	30	20	8	12	20	8	19	21
50	28	M20x2.5	24	M20x1.5	28	3/4-16	24	3/4-16	28	7/8-14	35	24	10	16	25	9	24	27
63	36	M27x3	30	M27x2	36	1-14	30	1-14	36	1 1/4-12	45	28	12	22	33	11	32	35
80	45	M33x3.5	35	M33x2	45	1 1/4-12	35	1 1/4-12	45	1 1/2-12	56	34	14	28	41	13	39	43
100	56	M42x4.5	45	M42x2	56	1 1/2-12	45	1 1/2-12	56	1 3/4-12	70	42	16	35	52	22	48	54

†Minimum 'W + Stroke' on V notch rod side may apply. See page 17 for details.

Rod End Dimensions

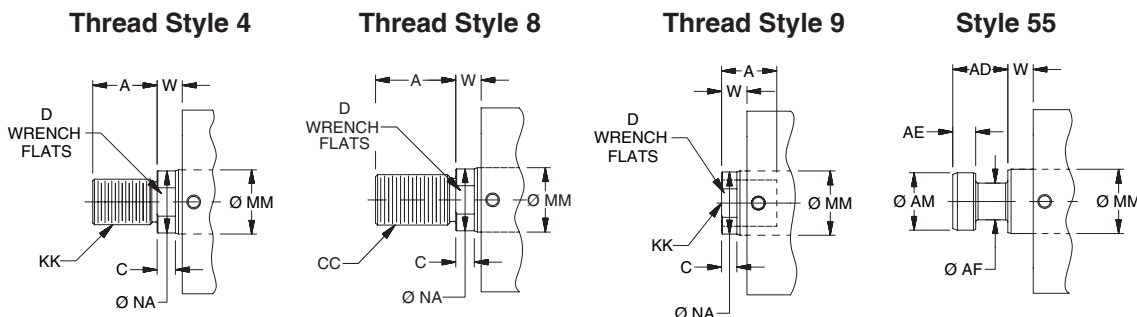

“Special” Thread Style 3
Special thread, extension, rod eye, blank, etc. are also available. To order, specify “Style 3” and give desired dimensions for KK, A, & W. If otherwise special furnish dimensional sketch.

TN and TR Mount – Single Rod End – 20mm to 100mm Bore Size

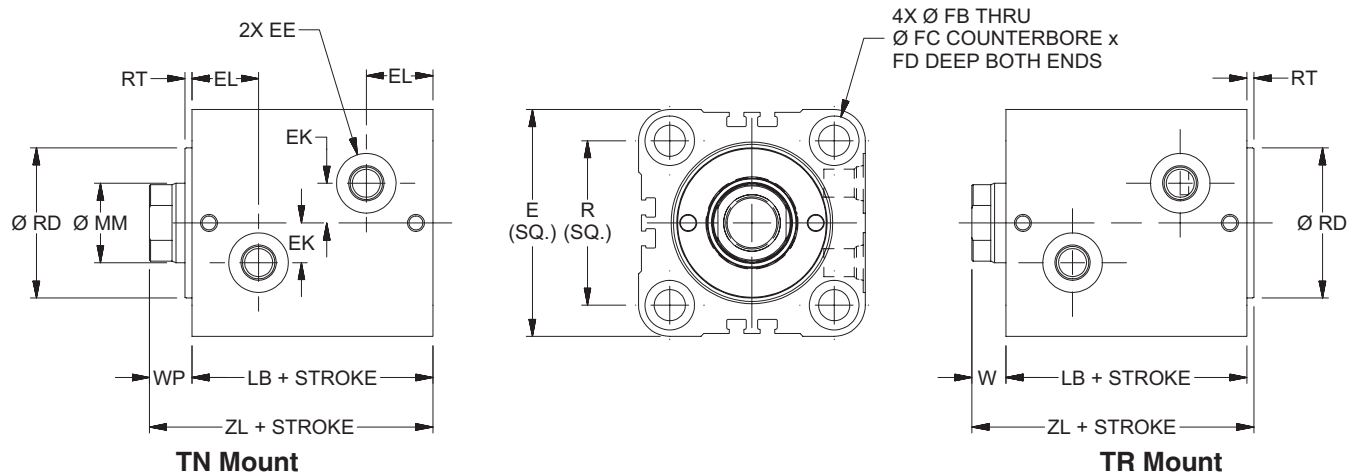

TN and TR Mount Single Rod End – Envelope and Mounting Dimensions

Bore Ø	E	EE			EK	EL	FB	FC	FD	LB	R	RD	RT	W	WP	ZL
		SAE	NPTF	BSP												
20	43*	#2	1/8	G-1/8	6	16.5	5.5	9.5	5.4	43	30	24	3	8	11	54
25	49	#2	1/8	G-1/8	8	17.5	5.5	9.5	5.4	45	36	27	3	8	11	56
32	62	#4	1/4	G-1/4	11	20.5	7	11	6.5	51	47	36	3	10	13	64
40	70	#4	1/4	G-1/4	12	21	9	14	8.6	55	52	43	3	10	13	68
50	80	#4	1/4	G-1/4	14	23.5	11	17.5	10.8	60	58	53	3	11	14	74
63	94	#4	1/4	G-1/4	17	26	13.5	20	13	67	69	66	3	13	16	83
80	114	#6	3/8	G-3/8	20	29.5	16	23	15.2	78	86	83	3	17	20	98
100	138	#6	3/8	G-3/8	25	35	18	26	17.5	96	106	103	3	26	29	125

*Port face on 20mm bore is extended 2mm. See port face extension drawing on [page 4](#).

TN and TR Mount Single Rod End – Rod Dimensions

Bore Ø	MM Rod Ø	Rod End														Rod Extension Dimensions		
		Style 9M		Style 4M		Style 9A		Style 4A		Style 8A		Style 55M						
		KK	A	KK	A	KK	A	KK	A	CC	A	AD	AE	AF	AM	C	D	NA
20	12	M8x1.25	10	M8x1	14	5/16-24	10	5/16-24	14	3/8-24	16	8	3	6	11	6	10	11
25	14	M10x1.5	12	M10x1.25	16	3/8-24	12	3/8-24	16	1/2-20	18	12	4	8	13	6	12	13
32	18	M12x1.75	15	M12x1.25	18	7/16-20	15	7/16-20	18	9/16-18	25	16	6	10	16	8	15	17
40	22	M16x2	20	M16x1.5	22	5/8-18	20	5/8-18	22	3/4-16	30	20	8	12	20	8	19	21
50	28	M20x2.5	24	M20x1.5	28	3/4-16	24	3/4-16	28	7/8-14	35	24	10	16	25	9	24	27
63	36	M27x3	30	M27x2	36	1-14	30	1-14	36	1 1/4-12	45	28	12	22	33	11	32	35
80	45	M33x3.5	35	M33x2	45	1 1/4-12	35	1 1/4-12	45	1 1/2-12	56	34	14	28	41	13	39	43
100	56	M42x4.5	45	M42x2	56	1 1/2-12	45	1 1/2-12	56	1 3/4-12	70	42	16	35	52	22	48	54

Rod End Dimensions

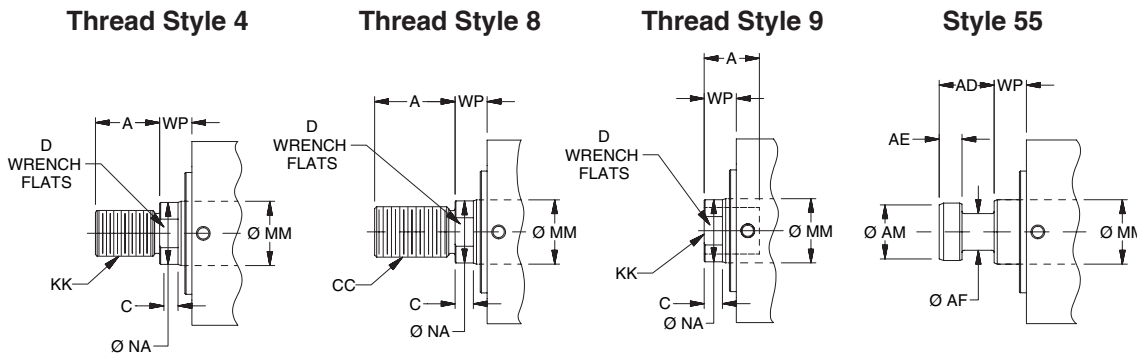

“Special” Thread Style 3
Special thread, extension, rod eye, blank, etc. are also available. To order, specify “Style 3” and give desired dimensions for KK, A, & W (TR Mount) or WP (TN Mount) If otherwise special furnish dimensional sketch.

TN Mount – Double Rod End – 20mm to 100mm Bore Size

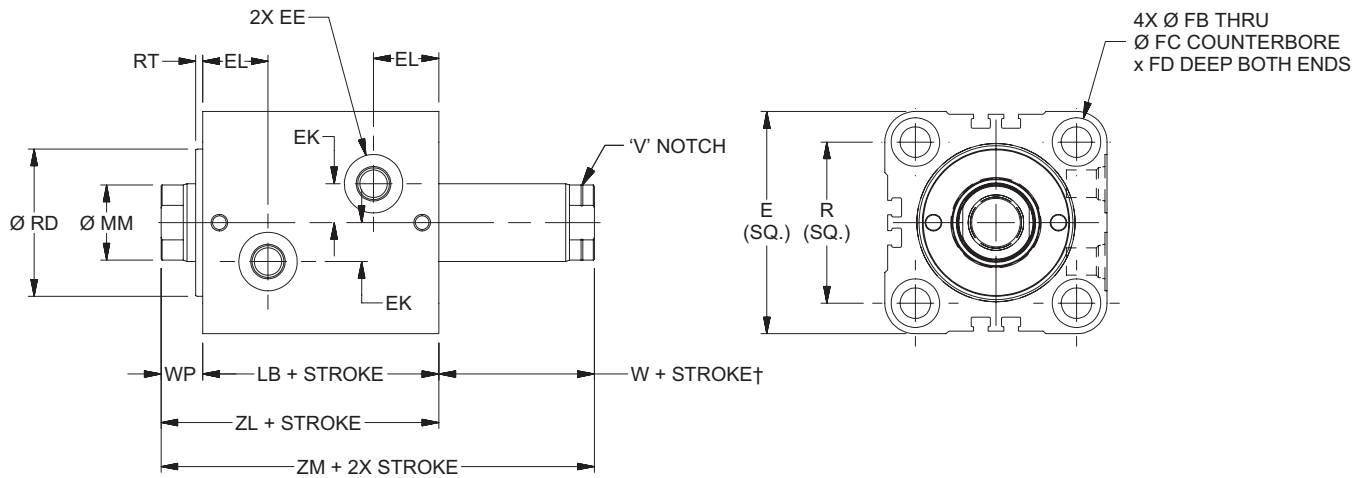

TN Mount Double Rod End – Envelope and Mounting Dimensions

Bore Ø	E	EE			EK	EL	FB	FC	FD	LB	R	RD f9	RT	W†	WP	ZL	ZM
		SAE	NPTF	BSP													
20	43*	#2	1/8	G-1/8	6	16.5	5.5	9.5	5.4	43	30	24	3	8	11	54	62
25	49	#2	1/8	G-1/8	8	17.5	5.5	9.5	5.4	45	36	27	3	8	11	56	64
32	62	#4	1/4	G-1/4	11	20.5	7	11	6.5	51	47	36	3	10	13	64	74
40	70	#4	1/4	G-1/4	12	21	9	14	8.6	55	52	43	3	10	13	68	78
50	80	#4	1/4	G-1/4	14	23.5	11	17.5	10.8	60	58	53	3	11	14	74	85
63	94	#4	1/4	G-1/4	17	26	13.5	20	13	67	69	66	3	13	16	83	96
80	114	#6	3/8	G-3/8	20	29.5	16	23	15.2	78	86	83	3	17	20	98	115
100	138	#6	3/8	G-3/8	25	35	18	26	17.5	96	106	103	3	26	29	125	151

*Port face on 20mm bore is extended 2mm. See port face extension drawing on [page 5](#).

TN Mount Double Rod End – Rod Dimensions

Bore Ø	MM Rod Ø	Rod End														Rod Extension Dimensions		
		Style 9M†		Style 4M		Style 9A†		Style 4A		Style 8A		Style 55M						
		KK	A	KK	A	KK	A	KK	A	CC	A	AD	AE	AF	AM	C	D	NA
20	12	M8x1.25	10	M8x1	14	5/16-24	10	5/16-24	14	3/8-24	16	8	3	6	11	6	10	11
25	14	M10x1.5	12	M10x1.25	16	3/8-24	12	3/8-24	16	1/2-20	18	12	4	8	13	6	12	13
32	18	M12x1.75	15	M12x1.25	18	7/16-20	15	7/16-20	18	9/16-18	25	16	6	10	16	8	15	17
40	22	M16x2	20	M16x1.5	22	5/8-18	20	5/8-18	22	3/4-16	30	20	8	12	20	8	19	21
50	28	M20x2.5	24	M20x1.5	28	3/4-16	24	3/4-16	28	7/8-14	35	24	10	16	25	9	24	27
63	36	M27x3	30	M27x2	36	1-14	30	1-14	36	1 1/4-12	45	28	12	22	33	11	32	35
80	45	M33x3.5	35	M33x2	45	1 1/4-12	35	1 1/4-12	45	1 1/2-12	56	34	14	28	41	13	39	43
100	56	M42x4.5	45	M42x2	56	1 1/2-12	45	1 1/2-12	56	1 3/4-12	70	42	16	35	52	22	48	54

†Minimum 'W + Stroke' on V notch rod side may apply. See [page 17](#) for details.

Rod End Dimensions

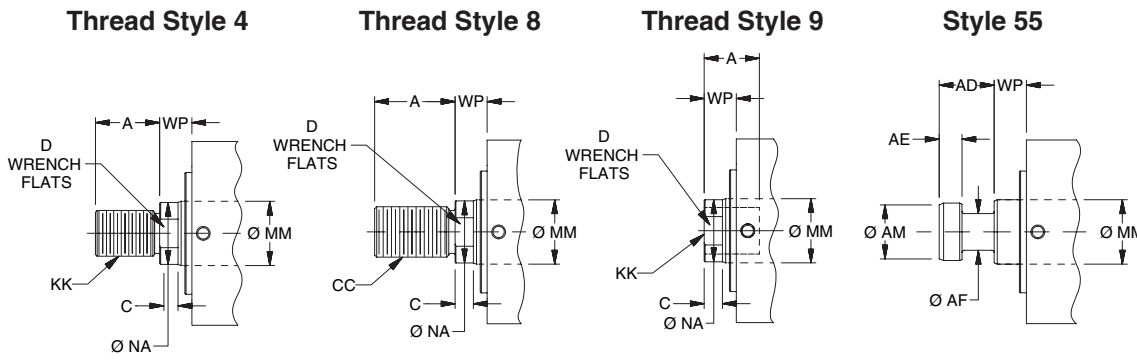

“Special” Thread Style 3
Special thread, extension, rod eye, blank, etc. are also available. To order, specify “Style 3” and give desired dimensions for KK, A, & WP. If otherwise special furnish dimensional sketch.

J & H Mounts – Single Rod End

J & H Mounts – Single Rod End – 20mm to 100mm Bore Size

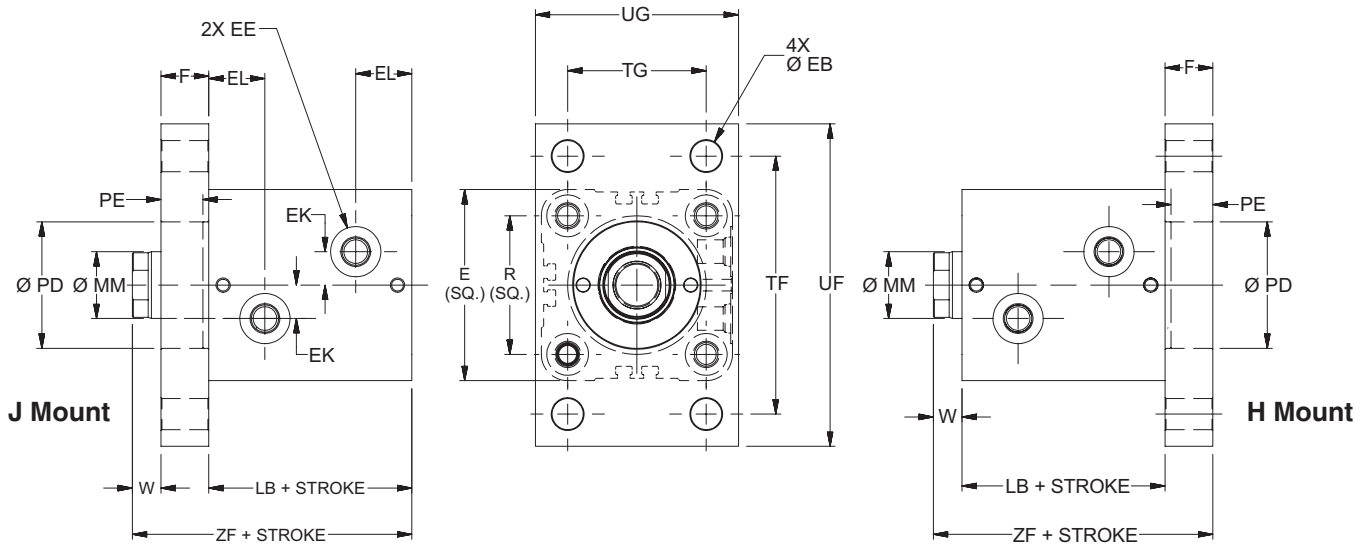

J & H Mounts Single Rod End – Envelope and Mounting Dimensions

Bore Ø	E	EE			EK	EL	F	EB	LB	PD H9	PE	R	TF	TG	UF	UG	W	ZF
		SAE	NPTF	BSP														
20	43*	#2	1/8	G-1/8	6	16.5	10	5.5	43	24	7	30	60	30	75	46	8	61
25	49	#2	1/8	G-1/8	8	17.5	12	5.5	45	27	9	36	66	36	80	52	8	65
32	62	#4	1/4	G-1/4	11	20.5	12	6.8	51	36	9	47	80	40	95	62	10	73
40	70	#4	1/4	G-1/4	12	21	16	11	55	43	13	52	96	46	118	70	10	81
50	80	#4	1/4	G-1/4	14	23.5	20	13.5	60	53	17	58	108	58	135	85	11	91
63	94	#4	1/4	G-1/4	17	26	20	16	67	66	17	69	124	65	150	98	13	100
80	114	#6	3/8	G-3/8	20	29.5	25	18	78	83	21	86	154	87	185	118	17	119
100	138	#6	3/8	G-3/8	25	35	30	22	96	103	27	106	190	109	230	150	26	152

*Port face on 20mm bore is extended 2mm. See port face extension drawing on [page 4](#).

J & H Mounts Single Rod End – Rod Dimensions

Bore Ø	MM Rod Ø	Rod End														Rod Extension Dimensions		
		Style 9M		Style 4M		Style 9A		Style 4A		Style 8A		Style 55M						
		KK	A	KK	A	KK	A	KK	A	CC	A	AD	AE	AF	AM	C	D	NA
20	12	M8x1.25	10	M8x1	14	5/16-24	10	5/16-24	14	3/8-24	16	8	3	6	11	6	10	11
25	14	M10x1.5	12	M10x1.25	16	3/8-24	12	3/8-24	16	1/2-20	18	12	4	8	13	6	12	13
32	18	M12x1.75	15	M12x1.25	18	7/16-20	15	7/16-20	18	9/16-18	25	16	6	10	16	8	15	17
40	22	M16x2	20	M16x1.5	22	5/8-18	20	5/8-18	22	3/4-16	30	20	8	12	20	8	19	21
50	28	M20x2.5	24	M20x1.5	28	3/4-16	24	3/4-16	28	7/8-14	35	24	10	16	25	9	24	27
63	36	M27x3	30	M27x2	36	1-14	30	1-14	36	1 1/4-12	45	28	12	22	33	11	32	35
80	45	M33x3.5	35	M33x2	45	1 1/4-12	35	1 1/4-12	45	1 1/2-12	56	34	14	28	41	13	39	43
100	56	M42x4.5	45	M42x2	56	1 1/2-12	45	1 1/2-12	56	1 3/4-12	70	42	16	35	52	22	48	54

Rod End Dimensions

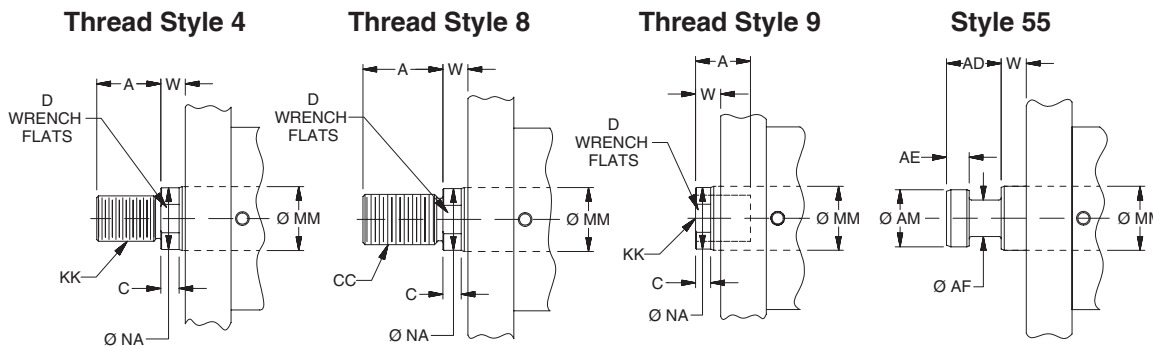

“Special” Thread Style 3
Special thread, extension, rod eye, blank, etc. are also available.
To order, specify “Style 3” and give desired dimensions for KK, A, & W. If otherwise special furnish dimensional sketch.

J Mount – Double Rod End – 20mm to 100mm Bore Size

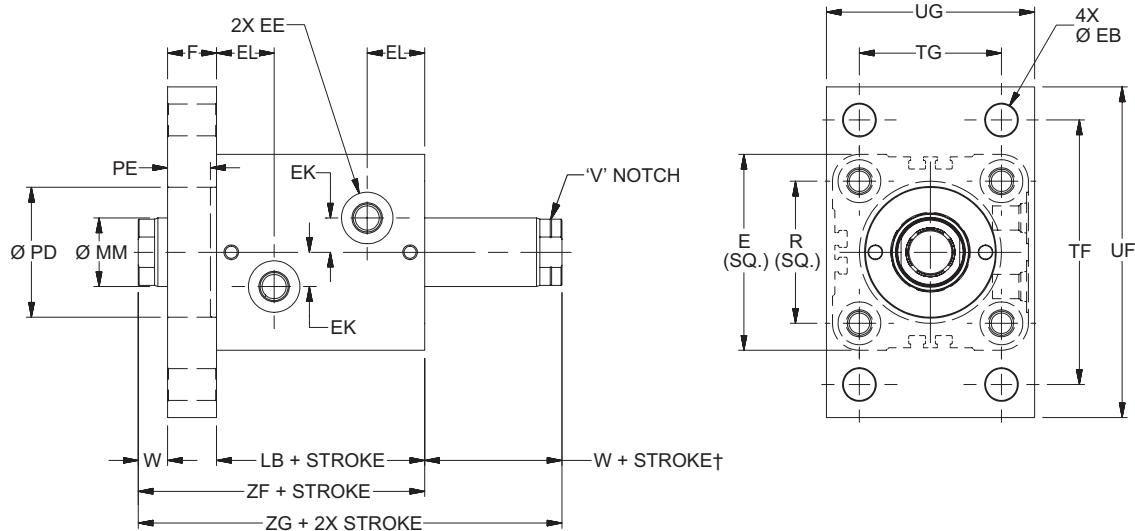

J Mount Double Rod End – Envelope and Mounting Dimensions

Bore Ø	E	EE			EK	EL	F	EB	LB	PD H9	PE	R	TF	TG	UF	UG	W†	ZF	ZG
		SAE	NPTF	BSP															
20	43*	#2	1/8	G-1/8	6	16.5	10	5.5	43	24	7	30	60	30	75	46	8	61	69
25	49	#2	1/8	G-1/8	8	17.5	12	5.5	45	27	9	36	66	36	80	52	8	65	73
32	62	#4	1/4	G-1/4	11	20.5	12	6.8	51	36	9	47	80	40	95	62	10	73	83
40	70	#4	1/4	G-1/4	12	21	16	11	55	43	13	52	96	46	118	70	10	81	91
50	80	#4	1/4	G-1/4	14	23.5	20	13.5	60	53	17	58	108	58	135	85	11	91	102
63	94	#4	1/4	G-1/4	17	26	20	16	67	66	17	69	124	65	150	98	13	100	113
80	114	#6	3/8	G-3/8	20	29.5	25	18	78	83	21	86	154	87	185	118	17	119	136
100	138	#6	3/8	G-3/8	25	35	30	22	96	103	27	106	190	109	230	150	26	152	178

*Port face on 20mm bore is extended 2mm. See port face extension drawing on page 5.

J Mount Double Rod End – Rod Dimensions

Bore Ø	MM Rod Ø	Rod End														Rod Extension Dimensions		
		Style 9M†		Style 4M		Style 9A†		Style 4A		Style 8A		Style 55M				C	D	NA
		KK	A	KK	A	KK	A	KK	A	CC	A	AD	AE	AF	AM			
20	12	M8x1.25	10	M8x1	14	5/16-24	10	5/16-24	14	3/8-24	16	8	3	6	11	6	10	11
25	14	M10x1.5	12	M10x1.25	16	3/8-24	12	3/8-24	16	1/2-20	18	12	4	8	13	6	12	13
32	18	M12x1.75	15	M12x1.25	18	7/16-20	15	7/16-20	18	9/16-18	25	16	6	10	16	8	15	17
40	22	M16x2	20	M16x1.5	22	5/8-18	20	5/8-18	22	3/4-16	30	20	8	12	20	8	19	21
50	28	M20x2.5	24	M20x1.5	28	3/4-16	24	3/4-16	28	7/8-14	35	24	10	16	25	9	24	27
63	36	M27x3	30	M27x2	36	1-14	30	1-14	36	1 1/4-12	45	28	12	22	33	11	32	35
80	45	M33x3.5	35	M33x2	45	1 1/4-12	35	1 1/4-12	45	1 1/2-12	56	34	14	28	41	13	39	43
100	56	M42x4.5	45	M42x2	56	1 1/2-12	45	1 1/2-12	56	1 3/4-12	70	42	16	35	52	22	48	54

†Minimum 'W + Stroke' on V notch rod side may apply. See page 17 for details.

Rod End Dimensions

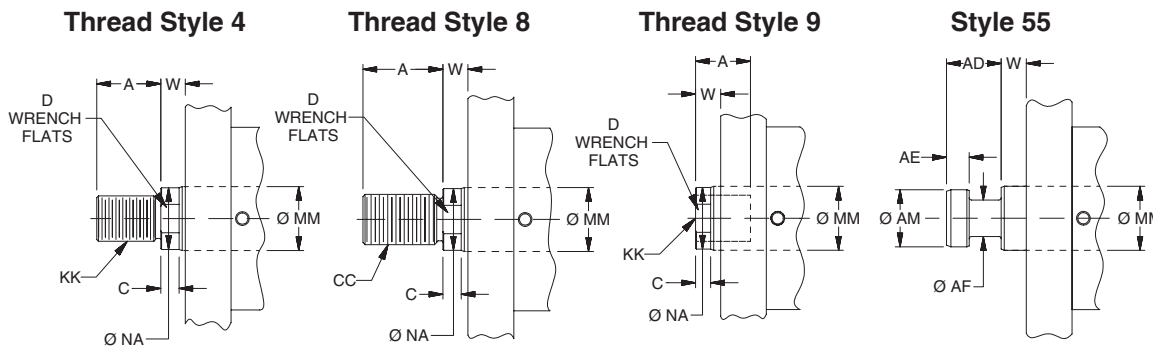

“Special” Thread Style 3
Special thread, extension, rod eye, blank, etc. are also available. To order, specify “Style 3” and give desired dimensions for KK, A, & W. If otherwise special furnish dimensional sketch.

CA Mount – Single Rod End – 20mm to 100mm Bore Size

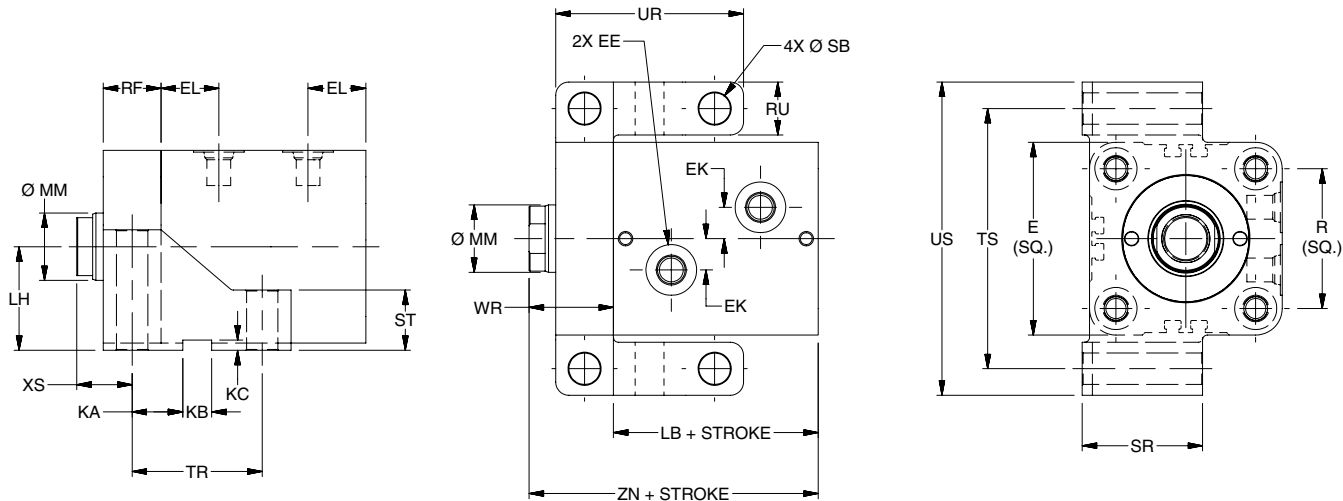

CA Mount Single Rod End – Envelope and Mounting Dimensions

Bore Ø	E	EE			EK	EL	KA	KB	KC	LH	LB	R	RF	RU	SB	SR	ST	TR	TS	UR	US	WR	XS	ZN
		SAE	NPTF	BSP																				
20	43*	#2	1/8	G-1/8	6	16.5	12	5	2.75	24	43	30	10	10	5.5	25	10	29	58	39	68	18	13	61
25	49	#2	1/8	G-1/8	8	17.5	13.5	6	3.25	27	45	36	12	12	6.8	30	12	33	66	45	78	20	14	65
32	62	#4	1/4	G-1/4	11	20.5	16.5	8	3.75	34	51	47	16	15	9	35	15	41	82	57	97	26	18	77
40	70	#4	1/4	G-1/4	12	21	18.5	10	4.25	38	55	52	20	18	11	40	20	47	94	67	112	30	20	85
50	80	#4	1/4	G-1/4	14	23.5	21	12	4.25	43	60	58	24	22	13.5	50	25	54	108	78	130	35	23	95
63	94	#4	1/4	G-1/4	17	26	25	14	4.75	51	67	69	28	26	16	60	30	64	128	92	154	41	27	108
80	114	#6	3/8	G-3/8	20	29.5	30	16	5.25	61	78	86	32	30	18	70	35	76	152	108	182	49	33	127
100	138	#6	3/8	G-3/8	25	35	36.5	20	6.25	75	96	106	38	36	22	80	40	93	186	131	222	64	45	160

*Port face on 20mm bore is extended 2mm. See port face extension drawing on page 4.

CA Mount Single Rod End – Rod Dimensions

Bore Ø	MM Rod Ø	Rod End														Rod Extension Dimensions		
		Style 9M		Style 4M		Style 9A		Style 4A		Style 8A		Style 55M				C	D	NA
		KK	A	KK	A	KK	A	KK	A	CC	A	AD	AE	AF	AM			
20	12	M8x1.25	10	M8x1	14	5/16-24	10	5/16-24	14	3/8-24	16	8	3	6	11	6	10	11
25	14	M10x1.5	12	M10x1.25	16	3/8-24	12	3/8-24	16	1/2-20	18	12	4	8	13	6	12	13
32	18	M12x1.75	15	M12x1.25	18	7/16-20	15	7/16-20	18	9/16-18	25	16	6	10	16	8	15	17
40	22	M16x2	20	M16x1.5	22	5/8-18	20	5/8-18	22	3/4-16	30	20	8	12	20	8	19	21
50	28	M20x2.5	24	M20x1.5	28	3/4-16	24	3/4-16	28	7/8-14	35	24	10	16	25	9	24	27
63	36	M27x3	30	M27x2	36	1-14	30	1-14	36	1 1/4-12	45	28	12	22	33	11	32	35
80	45	M33x3.5	35	M33x2	45	1 1/4-12	35	1 1/4-12	45	1 1/2-12	56	34	14	28	41	13	39	43
100	56	M42x4.5	45	M42x2	56	1 1/2-12	45	1 1/2-12	56	1 3/4-12	70	42	16	35	52	22	48	54

Rod End Dimensions

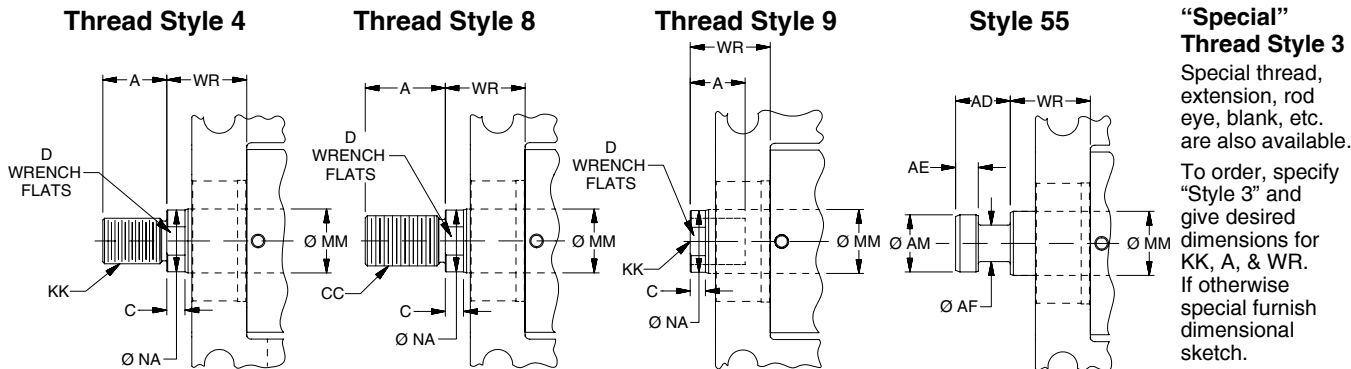

CA Mount – Double Rod End – 20mm to 100mm Bore Size

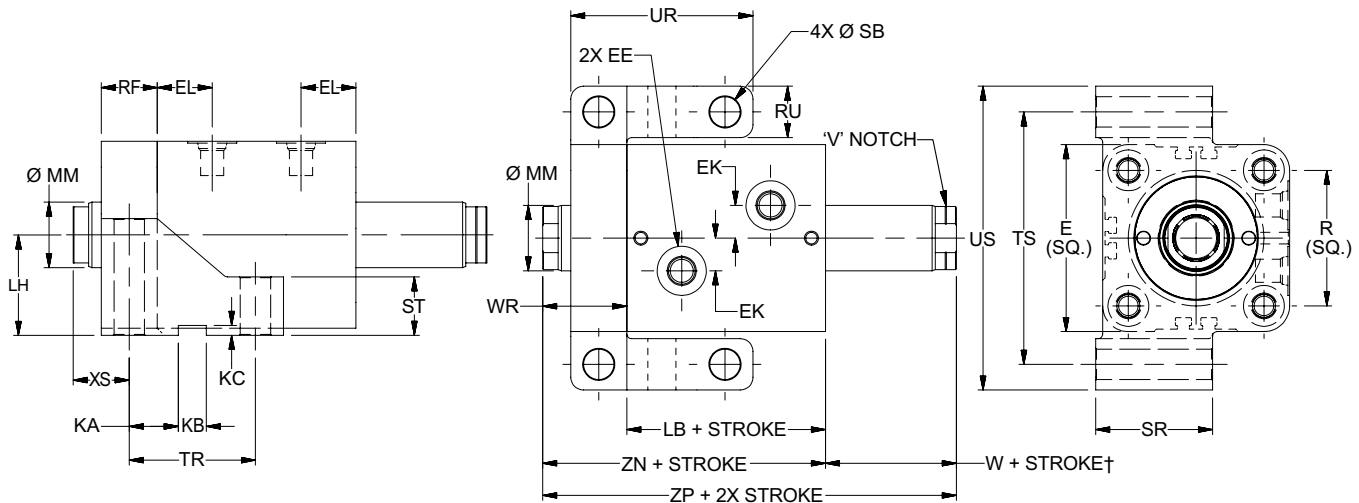

CA Mount Double Rod End – Envelope and Mounting Dimensions

Bore Ø	E	EE			EK	EL	KA	KB	KC	LB	LH	R	RF	RU	SB	SR	ST	TR	TS	UR	US	W †	WR	XS	ZN	ZP
		SAE	NPTF	BSP																						
20	43*	#2	1/8	G-1/8	6	16.5	12	5	2.75	43	24	30	10	10	5.5	25	10	29	58	39	68	8	18	13	61	69
25	49	#2	1/8	G-1/8	8	17.5	13.5	6	3.25	45	27	36	12	12	6.8	30	12	33	66	45	78	8	20	14	65	73
32	62	#4	1/4	G-1/4	11	20.5	16.5	8	3.75	51	34	47	16	15	9	35	15	41	82	57	97	10	26	18	77	87
40	70	#4	1/4	G-1/4	12	21	18.5	10	4.25	55	38	52	20	18	11	40	20	47	94	67	112	10	30	20	85	95
50	80	#4	1/4	G-1/4	14	23.5	21	12	4.25	60	43	58	24	22	13.5	50	25	54	108	78	130	11	35	23	95	106
63	94	#4	1/4	G-1/4	17	26	25	14	4.75	67	51	69	28	26	16	60	30	64	128	92	154	13	41	27	108	121
80	114	#6	3/8	G-3/8	20	29.5	30	16	5.25	78	61	86	32	30	18	70	35	76	152	108	182	17	49	33	127	144
100	138	#6	3/8	G-3/8	25	35	36.5	20	6.25	96	75	106	38	36	22	80	40	93	186	131	222	26	64	45	160	186

*Port face on 20mm bore is extended 2mm. See port face extension drawing on page 5.

CA Mount Double Rod End – Rod Dimensions

Bore Ø	MM Rod Ø	Rod End														Rod Extension Dimensions		
		Style 9M†		Style 4M		Style 9A†		Style 4A		Style 8A		Style 55M				C	D	NA
		KK	A	KK	A	KK	A	KK	A	CC	A	AD	AE	AF	AM			
20	12	M8x1.25	10	M8x1	14	5/16-24	10	5/16-24	14	3/8-24	16	8	3	6	11	6	10	11
25	14	M10x1.5	12	M10x1.25	16	3/8-24	12	3/8-24	16	1/2-20	18	12	4	8	13	6	12	13
32	18	M12x1.75	15	M12x1.25	18	7/16-20	15	7/16-20	18	9/16-18	25	16	6	10	16	8	15	17
40	22	M16x2	20	M16x1.5	22	5/8-18	20	5/8-18	22	3/4-16	30	20	8	12	20	8	19	21
50	28	M20x2.5	24	M20x1.5	28	3/4-16	24	3/4-16	28	7/8-14	35	24	10	16	25	9	24	27
63	36	M27x3	30	M27x2	36	1-14	30	1-14	36	1 1/4-12	45	28	12	22	33	11	32	35
80	45	M33x3.5	35	M33x2	45	1 1/4-12	35	1 1/4-12	45	1 1/2-12	56	34	14	28	41	13	39	43
100	56	M42x4.5	45	M42x2	56	1 1/2-12	45	1 1/2-12	56	1 3/4-12	70	42	16	35	52	22	48	54

†Minimum 'W + Stroke' on V notch rod side may apply. See page 17 for details.

Rod End Dimensions

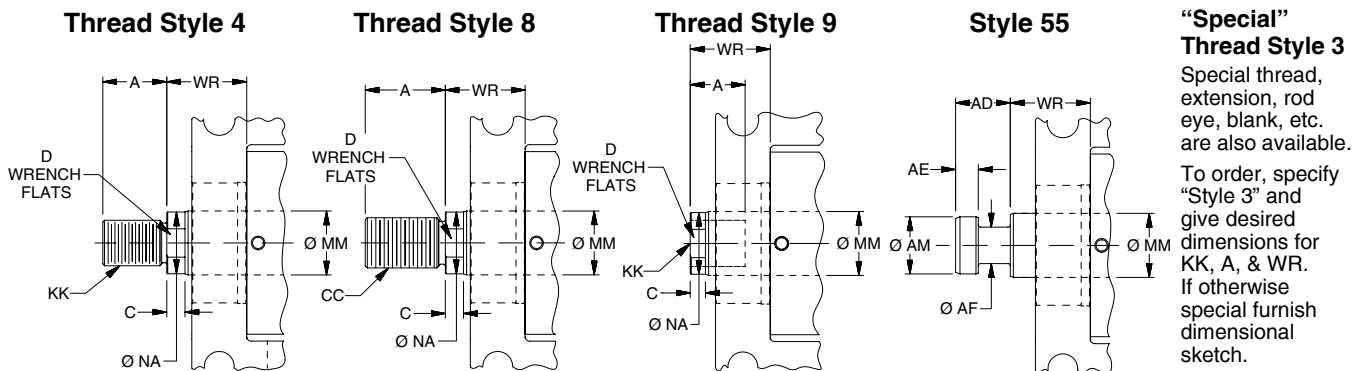

Global Position Sensing Switches



- Low Profile Keeps Switch Within Cylinder Envelope
- Both Reed and Solid State Switch Versions
- Switches Available World-Wide
- Solid State Switches use GMR Technology
- 5 Different Connection Styles
- Allow Position Sensing Anywhere Along Cylinder Stroke
- CE Approved

Solid State Switch Part Numbers

PNP	Wiring	NPN	Wiring
P8S-GPFLX	3m flying leads	P8S-GNFLX	3m flying leads
P8S-GPFTX	10m flying leads	P8S-GNFTX	10m flying leads
P8S-GPSHX	.2m lead with 8mm connector	P8S-GNSHX	.2m lead with 8mm connector
P8S-GPMHX	.2m lead with 12mm connector	P8S-GNMHX	.2m lead with 12mm connector
P8S-GPSCX	1m lead with 8mm connector	P8S-GNSCX	1m lead with 8mm connector

Solid State Switch Specifications

TypeElectronic
 Output Function.....Normally Open
 Switching Output.....PNP/NPN
 Operating Voltage.....10 - 30VDC
 Continuous Current.....100 mA max.
 Response Sensitivity.....2.8 mT min.
 Switching Frequency.....5 KHz
 Power Consumption.....10 mA max.
 Voltage Drop2 VDC max.
 Ripple10% of Operating Voltage
 Hysteresis1.5 mm max.
 Repeatability0.1 mm max.
 EMCEN 60 947-5-2
 Short-circuit Protection.....Yes
 Power-up Pulse SuppressionYes
 Reverse Polarity ProtectionYes
 Enclosure Rating.....IP 67
 Shock and Vibration Stress30g, 11 ms, 10 to 55 Hz, 1 mm
 Operating Temperature Range.....-25°C to +75°C (-13°F to 167°F)
 Housing MaterialPA 12, Black
 Connector CablePVC
 Connector.....PUR cable w/8 or 12 mm conn.

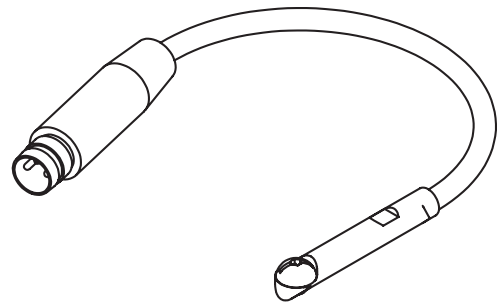

SOLID STATE SWITCH – WIRING CONNECTION

Flying Lead or 8 mm Connector (shown)	12 mm Connector																											
<table border="1" style="margin-left: auto; margin-right: auto;"> <thead> <tr> <th>Pin</th> <th>Wire</th> <th>Function</th> </tr> </thead> <tbody> <tr> <td>1</td> <td>Brown</td> <td>Operating Voltage</td> </tr> <tr> <td>2</td> <td>Black</td> <td>Output signal</td> </tr> <tr> <td>3</td> <td>Blue</td> <td>0V</td> </tr> </tbody> </table>	Pin	Wire	Function	1	Brown	Operating Voltage	2	Black	Output signal	3	Blue	0V	<table border="1" style="margin-left: auto; margin-right: auto;"> <thead> <tr> <th>PIN</th> <th>Wire</th> <th>Function</th> </tr> </thead> <tbody> <tr> <td>1</td> <td>brown</td> <td>Operating Voltage</td> </tr> <tr> <td>4</td> <td>black</td> <td>Not used</td> </tr> <tr> <td>2</td> <td>white</td> <td>Output Signal</td> </tr> <tr> <td>3</td> <td>blue</td> <td>0V</td> </tr> </tbody> </table>	PIN	Wire	Function	1	brown	Operating Voltage	4	black	Not used	2	white	Output Signal	3	blue	0V
Pin	Wire	Function																										
1	Brown	Operating Voltage																										
2	Black	Output signal																										
3	Blue	0V																										
PIN	Wire	Function																										
1	brown	Operating Voltage																										
4	black	Not used																										
2	white	Output Signal																										
3	blue	0V																										
<div style="display: flex; justify-content: space-around;"> <div style="text-align: center;"> <p>PNP</p> </div> <div style="text-align: center;"> <p>NPN</p> </div> </div>	<div style="display: flex; justify-content: space-around;"> <div style="text-align: center;"> <p>PNP</p> </div> <div style="text-align: center;"> <p>NPN</p> </div> </div>																											

Reed Switch Part Numbers

REED	Wiring
P8S-GRFLX	3m flying leads
P8S-GRFTX	10m flying leads
P8S-GRSHX	.2m lead with 8mm connector
P8S-GRMHX	.2m lead with 12mm connector
P8S-GRSCX	1m lead with 8mm connector

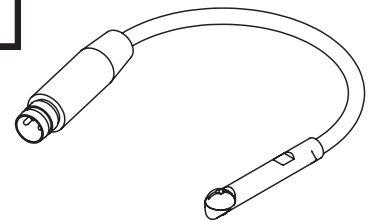

Reed Switch Specifications

Type Reed
 Output Function..... Normally Open
 Operating Voltage 10 - 120 VAC*
 10 - 30 VDC
 Continuous Current..... 100 mA max.
 Response Sensitivity..... 2.5 mT min.
 Switching Frequency..... 400 Kz
 Voltage Drop 3 V max.
 Ripple 10% of Operating Voltage
 Hysteresis 1.5 mm max.
 Repeatability 0.2 mm max.
 EMC EN 60 947-5-2
 Reverse Polarity Protection Yes
 Enclosure Rating..... IP 67
 Shock and Vibration Stress 30g, 11 ms, 10 to 55 Hz, 1 mm
 Operating Temperature Range..... -25°C to +75°C (-13°F to 167°F)
 Housing Material PA 12, Black
 Connector Cable PVC
 Connector..... PUR cable w/8 or 12 mm conn.

*8mm connector rated for 75 VAC max.

REED SWITCH - WIRING CONNECTION			
Flying Lead or 8 mm Connector			
	Pin	Wire	Function
	1	Brown	Operating Voltage
	2	White	Output signal
3	Blue	Not used	
12 mm Connector			
	Pin	Wire	Function
	1	Brown	Operating Voltage
	2	White	Output signal
	3	Blue	Not used
4	Black	Not used	

Circuit for Switching Contact Protection (Inductive Loads)

(Required for proper operation 24V DC)

Put Diode parallel to loads following polarity as shown below.

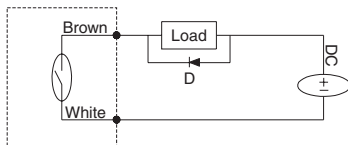

D: Diode: select a Diode with the breakdown voltage and current rating according to the load.

Typical Example—100 Volt, 1 Amp Diode
 CR: Relay coil (under 0.5W coil rating)

(Recommended for longer life 125 VAC)

Put a resistor and capacitor in parallel with the load. Select the resistor and capacitor according to the load.

Typical Example:
 CR: Relay coil (under 2W coil rating)
 R: Resistor 1 KΩ - 5 KΩ, 1/4 W
 C: Capacitor 0.1 μF, 600 V

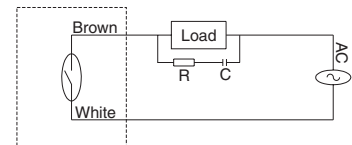

Caution

- Use an ammeter to test reed switch current. Testing devices such as incandescent light bulbs may subject the reed switch to high in-rush loads.
- **NOTE:** When checking an unpowered reed switch for continuity with a digital ohmmeter the resistance reading will change from infinity to a very large resistance (2 M ohm) when the switch is activated. This is due to the presence of a diode in the reed switch.
- Anti-magnetic shielding is recommended for reed switches exposed to high external RF or magnetic fields.
- The magnetic field strength of the piston magnet is designed to operate with our switches. Other manufacturers' switches or sensors may not operate correctly in conjunction with these magnets.
- Use relay coils for reed switch contact protection.
- The operation of some 120 VAC PLC's (especially some older Allen-Bradley PLC's) can overload the reed switch. The switch may fail to release after the piston magnet has passed. This problem may be corrected by the placement of a 700 to 1K OHM resistor between the switch and the PLC input terminal. Consult the manufacturer of the PLC for appropriate circuit.
- Switches with long wire leads (greater than 15 feet) can cause capacitance build-up and sticking will result. Attach a resistor in series with the reed switch (the resistor should be installed as close as possible to the switch). The resistor should be selected such that R (ohms) >E/0.3.

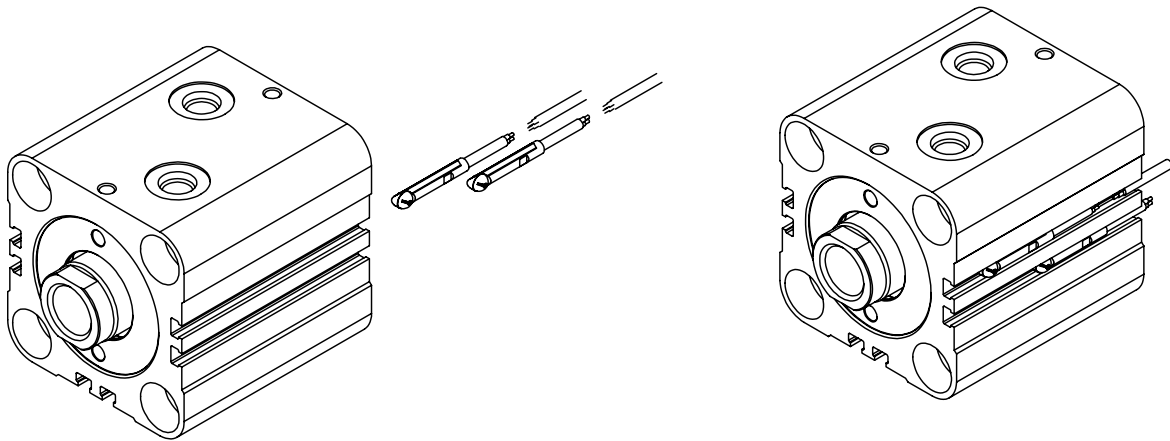

1. Slide the switch into any of the six mounting grooves provided.
2. For end of stroke sensing, position cross hairs of target symbol ⊕ on the switch at the specified distance from the cylinder body end as listed in the table below.
3. Locate the switch as required for intermediate stroke position sensing.
4. Turn the locking screw clockwise to secure the switch in place.

Minimum Stroke for Cylinders with Switches

All Bores	One Switch	Two Switches
	5mm	10mm

Switch Location for End-of-Stroke Sensing

Bore	A	B
20	17	26
25	18	27
32	20	30
40	21	34
50	23	36
63	26	41
80	29	49
100	36	60

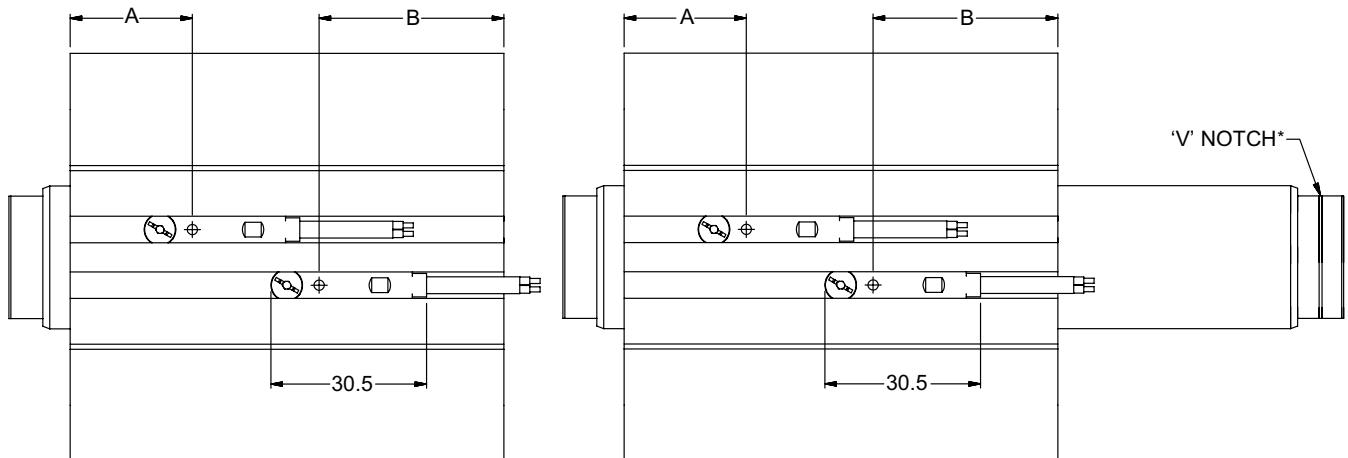

*The rod side for switch location 'B', on double rod end cylinders, is identified by a 'V' notch in the 'NA' diameter of rod end styles #4, #8, and #9. The 'V' notch will be in the 'AM' diameter of rod end style #55.

Cylinder Mounting

Always mount CHE cylinders using high tensile alloy steel socket head screws and torque them to the values shown. In addition to bolts, style CA cylinders should be keyed to the mounting surface with a thrust key, utilizing

the groove provided in the mounting bracket. Bolt kits for T, TN, and TR mounts are offered and can be specified by kit part numbers below.

Mounting Bolt Torques

Mount	Bore Ø	Mounting Bolt Size		Tightening Torque	
		Metric	Inch	N-m	ft. lbs.
T, TN, TR	20	M5 x 0.8	#10	4-5	3-4
	25	M5 x 0.8	#10	4-5	3-4
	32	M6 x 1.0	1/4	10-11	7-8
	40	M8 x 1.25	5/16	20-21	14-16
	50	M10 x 1.5	3/8	39-41	29-31
	63	M12 x 1.75	1/2	58-62	43-45
	80	M14 x 2.0	1/2*	88-92	64-68
J, H	100	M16 x 2.0	5/8	118-122	87-91
	20	M5 x 0.8	#10	4-5	3-4
	25	M5 x 0.8	#10	4-5	3-4
	32	M6 x 1.0	1/4	10-11	7-8
	40	M10 x 1.5	3/8	39-41	29-31
	50	M12 x 1.75	1/2	58-62	43-45
	63	M14 x 2.0	1/2*	88-92	64-68
CA	80	M16 x 2.0	5/8	118-122	87-91
	100	M20 x 2.5	3/4	178-182	131-135
	20	M5 x 0.8	#10	4-5	3-4
	25	M6 x 1.0	1/4	10-11	7-8
	32	M8 x 1.25	5/16	20-21	14-16
	40	M10 x 1.5	3/8	39-41	29-31
	50	M12 x 1.75	1/2	58-62	43-45
63	M14 x 2.0	1/2*	88-92	64-68	
80	M16 x 2.0	5/8	118-122	87-91	
100	M20 x 2.5	3/4	178-182	131-135	

* When using 1/2" socket head cap screws with 80mm T mount or 63mm CA, J and H mount, flat washers are required. Flat washer OD must be .866" ±.020 (22mm ±0.5).

Mounting Bolt Kits for Series CHE – Styles T, TN & TR (Kits include four bolts.)

Bore Ø	Bolt Size	Bolt Length	A Thread Length	Kit Part Number
20	M5 x 0.8	45mm + Stroke	7.4mm	CHEB020***
25	M5 x 0.8	50mm + Stroke	10.4mm	CHEB025***
32	M6 x 1.0	55mm + Stroke	10.5mm	CHEB032***
40	M8 x 1.25	60mm + Stroke	13.6mm	CHEB040***
50	M10 x 1.5	65mm + Stroke	15.8mm	CHEB050***
63	M12 x 1.75	70mm + Stroke	16.0mm	CHEB063***
80	M14 x 2.0	85mm + Stroke	22.2mm	CHEB080***
100	M16 x 2.0	105mm + Stroke	26.5mm	CHEB100***

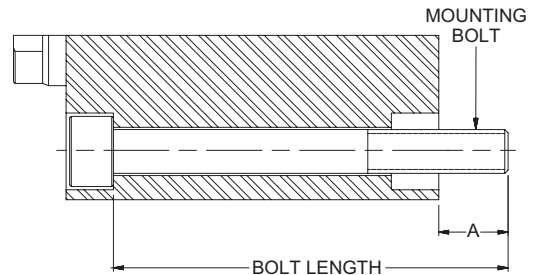

*** The last three digits of the kit part number are to be supplied as the cylinder stroke in 5mm increments. When specifying a bolt kit for intermediate stroke lengths, use the next longer 5mm stroke increment.

E.g. Kit number for 20mm bore, 35mm stroke – CHEB020035
 Kit number for 50mm bore, 72mm stroke – CHEB050075

For intermediate stroke lengths the 'A' exposed thread length will be therefore increased by the difference between the actual stroke and the next longer 5mm bolt stroke length increment.

Parts Identification Drawing – Standard Piston

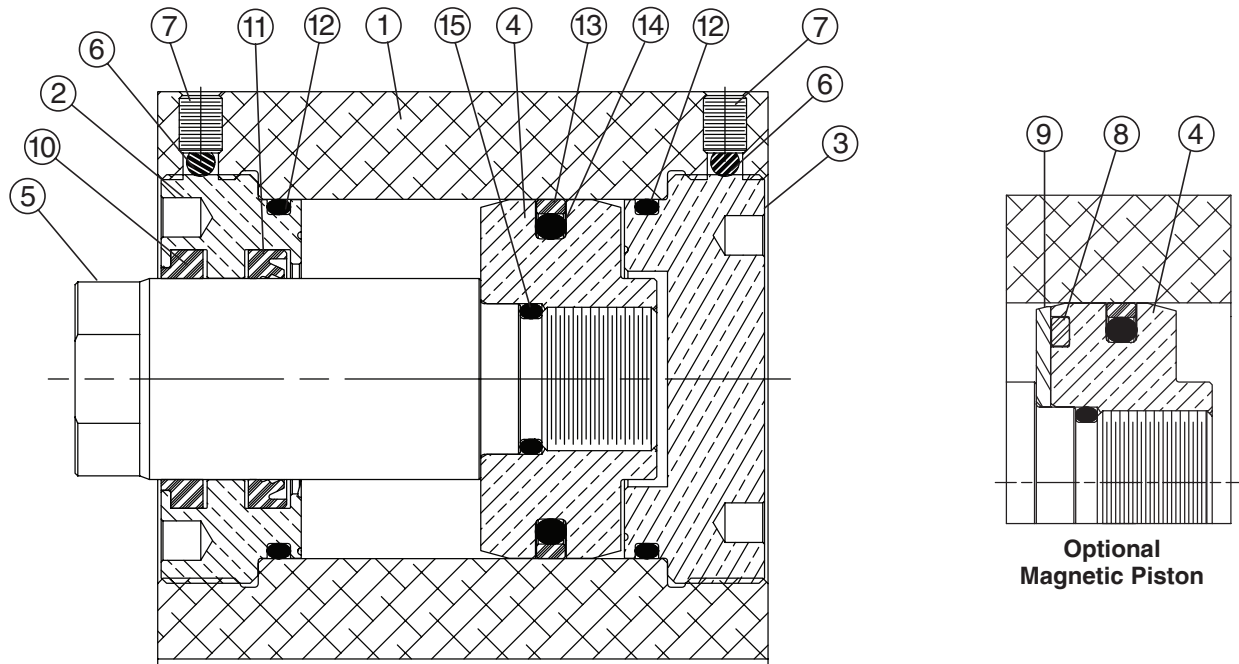

Item No.	Description	Material	Item No.	Description	Material	
					Standard	Fluorocarbon
1	Cylinder Body	Aluminum Alloy (Hard Anodized)	10	Rod Wiper	PUR	Fluorocarbon
2	Gland	Bronze	11	Rod Seal	PUR	Fluorocarbon
3	Cap	Bronze*	12	End Seal	NBR	Fluorocarbon
4	Piston	Bronze	13	Piston Seal	PUR	Filled PTFE
5	Piston Rod	Carbon Steel (Hard Chrome Plated)	14	PS Energizer	NBR	Fluorocarbon
6	Ball	Nylon	15	Piston-to- Rod o-ring	NBR	Fluorocarbon
7	Set Screw	Alloy Steel				
8	Magnet	Sintered NdFeB**				
9	Magnet Retainer	Stainless Steel				

*Aluminum alloy on 80mm & 100mm bores

**Neodymium Iron Boron

Minimum Rod Extension

Double rod cylinders with Style 9 on V notch side of cylinder

When a rod end Style 9 is specified on the V notch side of a double rod cylinder, a minimum W + Stroke dimension is required. This bore and stroke dependent value is shown in the following table.

Bore Ø	Minimum W + Stroke	For Strokes Equal-to or Less-than
20	18	10
25	23	15
32	25	15
40	30	20
50	31	20
63	38	25
80	42	25
100	51	25

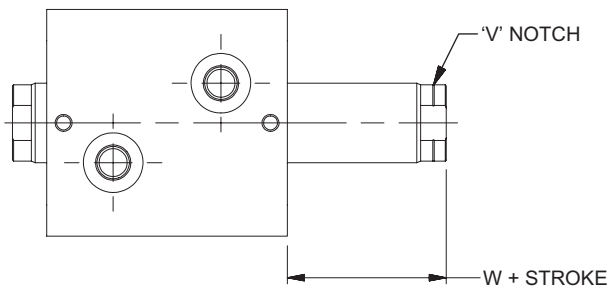

Style 3 (special) rod ends with female thread depth equal to the standard A dimension are also subject to this minimum. For deeper threads, the minimum W + Stroke will increase by the depth increase beyond the standard A dimension. No other rod end styles have this limitation.

Seal Kits / Gland & Cap Spanner Holes

Seal Kits

See Standard Specifications Page for fluid and temperature compatibility. Cylinder gland and cap are threaded into the cylinder body. To service rod seal, rod wiper, piston seal, or end seals the gland or cap must be removed. Spanner holes in the gland and cap

are available for the purpose of removing and installing these components. Be sure to torque the gland or cap to the specifications below and replace the nylon ball and set screw to further lock them in place.

Rod Gland and Rod Seal Kits

Rod Ø	Rod Gland (w/o pilot*) Kits		Rod Seal Kits	
	Class 1	Class 5	Class 1	Class 5
	Consists of 1 ea. of items #2, 6, 10, 11, & 12		Consists of 1 ea. of items #6, 10, 11, & 12	
12	CH12RH000	CV12RH000	CH12SH000	CV12SH000
14	CH14RH000	CV14RH000	CH14SH000	CV14SH000
18	CH18RH000	CV18RH000	CH18SH000	CV18SH000
22	CH22RH000	CV22RH000	CH22SH000	CV22SH000
28	CH28RH000	CV28RH000	CH28SH000	CV28SH000
36	CH36RH000	CV36RH000	CH36SH000	CV36SH000
45	CH45RH000	CV45RH000	CH45SH000	CV45SH000
56	CH56RH000	CV56RH000	CH56SH000	CV56SH000

* Pilot gland is required for TN, J, and CA mounting styles. For Gland Kit with pilot change 'RH' in kit number to 'RP'. For example: CH12RP000

Complete Seal Kits

Bore Ø	Class 1	Class 5	Gland & Cap Torque Specifications	
	Consists of 1 ea. of items #10, 11, 13, 14, & 2 ea. of items #6 & 12		N-m	ft. lbs.
20	CH12SK020	CV12SK020	11 - 12	8 - 9
25	CH14SK025	CV14SK025	17 - 18	12 - 13
32	CH18SK032	CV18SK032	27 - 32	28 - 32
40	CH22SK040	CV22SK040	72 - 77	53 - 57
50	CH28SK050	CV28SK050	119 - 125	88 - 92
63	CH36SK063	CV36SK063	241 - 247	178 - 182
80	CH45SK080	CV45SK080	472 - 478	348 - 352
100	CH56SK100	CV56SK100	878 - 884	648 - 652

Spanner Hole Dimensions

Gland Spanners

Bore Ø	CC	DD	FF
20	2.25	2.5	22
25	2.75	3	25
32	3.5	3.5	30
40	4.5	4.5	35
50	5.5	5.5	45
63	6.5	6.5	55
80	8.5	8.5	70
100	10.5	10.5	85

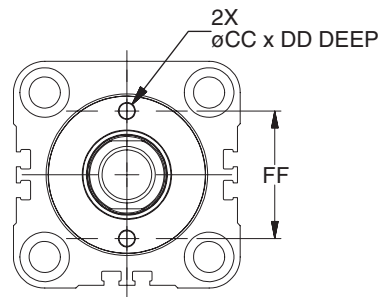

Cap Spanners

Bore Ø	CC	DD	FF
20	2.25	2.5	15
25	2.75	3	18
32	3.5	3.5	25
40	4.5	4.5	32
50	5.5	5.5	40
63	6.5	6.5	50
80	8.5	8.5	63
100	10.5	10.5	80

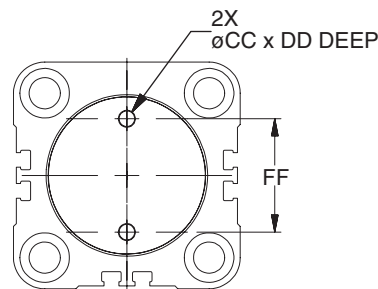

Safety Guide for Selecting and Using Hydraulic, Pneumatic Cylinders and Their Accessories

WARNING: ⚠ **FAILURE OF THE CYLINDER, ITS PARTS, ITS MOUNTING, ITS CONNECTIONS TO OTHER OBJECTS, OR ITS CONTROLS CAN RESULT IN:**

- Unanticipated or uncontrolled movement of the cylinder or objects connected to it.
- Falling of the cylinder or objects held up by it.
- Fluid escaping from the cylinder, potentially at high velocity.

THESE EVENTS COULD CAUSE DEATH OR PERSONAL INJURY BY, FOR EXAMPLE, PERSONS FALLING FROM HIGH LOCATIONS, BEING CRUSHED OR STRUCK BY HEAVY OR FAST MOVING OBJECTS, BEING PUSHED INTO DANGEROUS EQUIPMENT OR SITUATIONS, OR SLIPPING ON ESCAPED FLUID.

Before selecting or using Atlas (The Company) cylinders or related accessories, it is important that you read, understand and follow the following safety information. Training is advised before selecting and using The Company's products.

1.0 General Instructions

1.1 Scope – This safety guide provides instructions for selecting and using (including assembling, installing, and maintaining) cylinder products. This safety guide is a supplement to and is to be used with the specific Company publications for the specific cylinder products that are being considered for use.

1.2 Fail Safe – Cylinder products can and do fail without warning for many reasons. All systems and equipment should be designed in a fail-safe mode so that if the failure of a cylinder product occurs people and property won't be endangered.

1.3 Distribution – Provide a free copy of this safety guide to each person responsible for selecting or using cylinder products. Do not select or use The Company's cylinders without thoroughly reading and understanding this safety guide as well as the specific Company publications for the products considered or selected.

1.4 User Responsibility – Due to very wide variety of cylinder applications and cylinder operating conditions, The Company does not warrant that any particular cylinder is suitable for any specific application. This safety guide does not analyze all technical parameters that must be considered in selecting a product. The hydraulic and pneumatic cylinders outlined in this catalog are designed to The Company's design guidelines and do not necessarily meet the design guideline of other agencies such as American Bureau of Shipping, ASME Pressure Vessel Code etc. The user, through its own analysis and testing, is solely responsible for:

- Making the final selection of the cylinders and related accessories.
- Determining if the cylinders are required to meet specific design requirements as required by the Agency(s) or industry standards covering the design of the user's equipment.
- Assuring that the user's requirements are met, OSHA requirements are met, and safety guidelines from the applicable agencies such as but not limited to ANSI are followed and that the use presents no health or safety hazards.
- Providing all appropriate health and safety warnings on the equipment on which the cylinders are used.

1.5 Additional Questions – Call the appropriate Company technical service department if you have any questions or require any additional information. See the Company publication for the product being considered or used, or call the number on the back cover of this catalog for the technical service department.

2.0 Cylinder and Accessories Selection

2.1 Seals – Part of the process of selecting a cylinder is the selection of seal compounds. Before making this selection, consult the "seal information page(s)" of the publication for the series of cylinders of interest.

The application of cylinders may allow fluids such as cutting fluids, wash down fluids etc. to come in contact with the external area of the cylinder. These fluids may attack the piston rod wiper and or the primary seal and must be taken into account when selecting and specifying seal compounds.

Dynamic seals will wear. The rate of wear will depend on many operating factors. Wear can be rapid if a cylinder is mis-aligned or if the cylinder has been improperly serviced. The user must take seal wear into consideration in the application of cylinders.

2.2 Piston Rods – Possible consequences of piston rod failure or separation of the piston rod from the piston include, but are not limited to are:

- Piston rod and or attached load thrown off at high speed.
- High velocity fluid discharge.
- Piston rod extending when pressure is applied in the piston retract mode.

Piston rods or machine members attached to the piston rod may move suddenly and without warning as a consequence of other conditions occurring to the machine such as, but not limited to:

- Unexpected detachment of the machine member from the piston rod.

- Failure of the pressurized fluid delivery system (hoses, fittings, valves, pumps, compressors) which maintain cylinder position.
- Catastrophic cylinder seal failure leading to sudden loss of pressurized fluid.
- Failure of the machine control system.

Follow the recommendations of the "Piston Rod Selection Chart and Data" in the publication for the series of cylinders of interest. The suggested piston rod diameter in these charts must be followed in order to avoid piston rod buckling.

Piston rods are not normally designed to absorb bending moments or loads which are perpendicular to the axis of piston rod motion. These additional loads can cause the piston rod to fail. If these types of additional loads are expected to be imposed on the piston rod, their magnitude should be made known to our engineering department.

The cylinder user should always make sure that the piston rod is securely attached to the machine member.

On occasion cylinders are ordered with double rods (a piston rod extended from both ends of the cylinder). In some cases a stop is threaded on to one of the piston rods and used as an external stroke adjuster. On occasions spacers are attached to the machine member connected to the piston rod and also used as a stroke adjuster. In both cases the stops will create a pinch point and the user should consider appropriate use of guards. If these external stops are not perpendicular to the mating contact surface, or if debris is trapped between the contact surfaces, a bending moment will be placed on the piston rod, which can lead to piston rod failure. An external stop will also negate the effect of cushioning and will subject the piston rod to impact loading. Those two (2) conditions can cause piston rod failure. Internal stroke adjusters are available with and without cushions. The use of external stroke adjusters should be reviewed with our engineering department.

The piston rod to piston and the stud to piston rod threaded connections are secured with an anaerobic adhesive. The strength of the adhesive decreases with increasing temperature. Cylinders which can be exposed to temperatures above +250°F (+121°C) are to be ordered with a non studded piston rod and a pinned piston to rod joint.

2.3 Cushions – Cushions should be considered for cylinder applications when the piston velocity is expected to be over 4 inches/second.

Cylinder cushions are normally designed to absorb the energy of a linear applied load. A rotating mass has considerably more energy than the same mass moving in a linear mode. Cushioning for a rotating mass application should be reviewed by our engineering department.

2.4 Cylinder Mountings – Some cylinder mounting configurations may have certain limitations such as but not limited to minimum stroke for side or foot mounting cylinders or pressure de-ratings for certain mounts. Carefully review the catalog for these types of restrictions.

Always mount cylinders using the largest possible high tensile alloy steel socket head cap screws that can fit in the cylinder mounting holes and torque them to the manufacturer's recommendations for their size.

2.5 Port Fittings – Hydraulic cylinders applied with meter out or deceleration circuits are subject to intensified pressure at piston rod end.

The rod end pressure is approximately equal to:

$$\frac{\text{operating pressure} \times \text{effective cap end area}}{\text{effective rod end piston area}}$$

Contact your connector supplier for the pressure rating of individual connectors.

3.0 Cylinder and Accessories Installation and Mounting

3.1 Installation

3.1.1 – Cleanliness is an important consideration, and cylinders are shipped with the ports plugged to protect them from contaminants entering the ports. These plugs should not be removed until the piping is to be installed. Before making the connection to the cylinder ports, piping should be thoroughly cleaned to remove all chips or burrs which might have resulted from threading or flaring operations.

3.1.2 – Cylinders operating in an environment where air drying materials are present such as fast-drying chemicals, paint, or weld splatter, or other hazardous conditions such as excessive heat, should have shields installed to prevent damage to the piston rod and piston rod seals.

3.1.3 – Proper alignment of the cylinder piston rod and its mating component on the machine should be checked in both the extended and retracted positions. Improper alignment will result in excessive rod gland and/or cylinder bore wear. On fixed mounting cylinders attaching the piston rod while the rod is retracted will help in achieving proper alignment.

3.1.4 – Sometimes it may be necessary to rotate the piston rod in order to thread the piston rod into the machine member. This operation must always be done with zero pressure being applied to either side of the piston. Failure to follow this procedure may result in loosening the piston to rod-threaded connection. In some rare cases the turning of the piston rod may rotate a threaded piston rod gland and loosen it from the cylinder head. Confirm that this condition is not occurring. If it does, re-tighten the piston rod gland firmly against the cylinder head.

For double rod cylinders it is also important that when attaching or detaching the piston rod from the machine member that the torque be applied to the piston rod end of the cylinder that is directly attaching to the machine member with the opposite end unrestrained. If the design of the machine is such that only the rod end of the cylinder opposite to where the rod attaches to the machine member can be rotated, consult the factory for further instructions.

3.2 Mounting Recommendations

3.2.1 – Always mount cylinders using the largest possible high tensile alloy steel socket head screws that can fit in the cylinder mounting holes and torque them to the manufacturer's recommendations for their size.

3.2.2 – Side-Mounted Cylinders – In addition to the mounting bolts, cylinders of this type should be equipped with thrust keys or dowel pins located so as to resist the major load.

3.2.3 – Tie Rod Mounting – Cylinders with tie rod mountings are recommended for applications where mounting space is limited. The standard tie rod extension is shown as BB in dimension tables. Longer or shorter extensions can be supplied. Nuts used for this mounting style should be torqued to the same value as the tie rods for that bore size.

3.2.4 – Flange Mount Cylinders – The controlled diameter of the rod gland extension on head end flange mount cylinders can be used as a pilot to locate the cylinders in relation to the machine. After alignment has been obtained, the flanges may be drilled for pins or dowels to prevent shifting.

3.2.5 – Trunnion Mountings – Cylinders require lubricated bearing blocks with minimum bearing clearances. Bearing blocks should be carefully aligned and rigidly mounted so the trunnions will not be subjected to bending moments. The rod end should also be pivoted with the pivot pin in line and parallel to axis of the trunnion pins.

3.2.6 – Clevis Mountings – Cylinders should be pivoted at both ends with centerline of pins parallel to each other. After cylinder is mounted, be sure to check to assure that the cylinder is free to swing through its working arc without interference from other machine parts.

4.0 Cylinder and Accessories Maintenance, Troubleshooting and Replacement

4.1 Storage – At times cylinders are delivered before a customer is ready to install them and must be stored for a period of time. When storage is required the following procedures are recommended.

4.1.1 – Store the cylinders in an indoor area which has a dry, clean and noncorrosive atmosphere. Take care to protect the cylinder from both internal corrosion and external damage.

4.1.2 – Whenever possible cylinders should be stored in a vertical position (piston rod up). This will minimize corrosion due to possible condensation which could occur inside the cylinder. This will also minimize seal damage.

4.1.3 – Port protector plugs should be left in the cylinder until the time of installation.

4.1.4 – If a cylinder is stored full of hydraulic fluid, expansion of the fluid due to temperature changes must be considered. Installing a check valve with free flow out of the cylinder is one method.

4.1.5 – When cylinders are mounted on equipment that is stored outside for extended periods, exposed unpainted surfaces, e.g. piston rod, must be coated with a rust-inhibiting compound to prevent corrosion.

4.2 Cylinder Trouble Shooting

4.2.1 – External Leakage

4.2.1.1 – Rod seal leakage can generally be traced to worn or damaged seals. Examine the piston rod for dents, gouges or score marks, and replace piston rod if surface is rough.

Rod seal leakage could also be traced to gland wear. If clearance is excessive, replace rod bushing and seal. Rod seal leakage can also be traced to seal deterioration. If seals are soft or gummy or brittle, check compatibility of seal material with lubricant used if air cylinder, or operating fluid if hydraulic cylinder. Replace with seal material, which is compatible with these fluids. If the seals are hard or have lost elasticity, it is usually due to exposure to temperatures in excess of 165°F. (+74°C). Shield the cylinder from the heat source to limit temperature to 350°F. (+177°C.) and replace with fluorocarbon seals.

4.2.1.2 – Cylinder body seal leak can generally be traced to loose tie rods. Torque the tie rods to manufacturer's recommendation for that bore size.

Excessive pressure can also result in cylinder body seal leak. Determine maximum pressure to rated limits. Replace seals and retorque tie rods as in paragraph above. Excessive pressure can also result in cylinder body seal leak. Determine if the pressure rating of the cylinder has been exceeded. If so, bring the operating pressure down to the rating of the cylinder and have the tie rods replaced.

Pinched or extruded cylinder body seal will also result in a leak. Replace cylinder body seal and retorque as in paragraph above.

Cylinder body seal leakage due to loss of radial squeeze which shows up in the form of flat spots or due to wear on the O.D. or I.D. – Either of these are symptoms of normal wear due to high cycle rate or length of service. Replace seals as per paragraph above.

4.2.2 – Internal Leakage

4.2.2.1 – Piston seal leak (by-pass) 1 to 3 cubic inches per minute leakage is considered normal for piston ring construction. Virtually no static leak with lipseal type seals on piston should be expected. Piston seal wear is a usual cause of piston seal leakage. Replace seals as required.

4.2.2.2 – With lipseal type piston seals excessive back pressure due to over-adjustment of speed control valves could be a direct cause of rapid seal wear. Contamination in a hydraulic system can result in a scored cylinder bore, resulting in rapid seal wear. In either case, replace piston seals as required.

4.2.2.3 – What appears to be piston seal leak, evidenced by the fact that the cylinder drifts, is not always traceable to the piston. To make sure, it is suggested that one side of the cylinder piston be pressurized and the fluid line at the opposite port be disconnected. Observe leakage. If none is evident, seek the cause of cylinder drift in other component parts in the circuit.

4.2.3 – Cylinder Fails to Move the Load

4.2.3.1 – Pneumatic or hydraulic pressure is too low. Check the pressure at the cylinder to make sure it is to circuit requirements.

4.2.3.2 – Piston Seal Leak – Operate the valve to cycle the cylinder and observe fluid flow at valve exhaust ports at end of cylinder stroke. Replace piston seals if flow is excessive.

4.2.3.3 – Cylinder is undersized for the load – Replace cylinder with one of a larger bore size.

4.3 Erratic or Chatter Operation

4.3.1 – Excessive friction at rod gland or piston bearing due to load misalignment – Correct cylinder-to-load alignment.

4.3.2 – Cylinder sized too close to load requirements – Reduce load or install larger cylinder.

4.3.3 – Erratic operation could be traced to the difference between static and kinetic friction. Install speed control valves to provide a back pressure to control the stroke.

4.4 Cylinder Modifications, Repairs, or Failed Component – Cylinders as shipped from the factory are not to be disassembled and or modified. If cylinders require modifications, these modifications must be done at company locations or by The Company's certified facilities. The Cylinder Division Engineering Department must be notified in the event of a mechanical fracture or permanent deformation of any cylinder component (excluding seals). This includes a broken piston rod, tie rod, mounting accessory or any other cylinder component. The notification should include all operation and application details. This information will be used to provide an engineered repair that will prevent recurrence of the failure.

It is allowed to disassemble cylinders for the purpose of replacing seals or seal assemblies. However, this work must be done by strictly following all the instructions provided with the seal kits.

Offer of Sale

The items described in this document and other documents or descriptions provided by the Company, its subsidiaries and its authorized distributors, are hereby offered for sale at prices to be established by the Company, its subsidiaries and its authorized distributors. This offer and its acceptance by any customer ("Buyer") shall be governed by all of the following Terms and Conditions. Buyer's order for any such item, when communicated to the Company, its subsidiaries or an authorized distributor ("Seller") verbally or in writing, shall constitute acceptance of this offer.

1. Terms and Conditions of Sale: All descriptions, quotations, proposals, offers, acknowledgments, acceptances and sales of Seller's products are subject to and shall be governed exclusively by the terms and conditions stated herein. Buyer's acceptance of any offer to sell is limited to these terms and conditions. Any terms or conditions in addition to, or inconsistent with those stated herein, proposed by Buyer in any acceptance of an offer by Seller, are hereby objected to. No such additional, different or inconsistent terms and conditions shall become part of the contract between Buyer and Seller unless expressly accepted in writing by Seller. Seller's acceptance of any offer to purchase by Buyer is expressly conditional upon Buyer's assent to all the terms and conditions stated herein, including any terms in addition to, or inconsistent with those contained in Buyer's offer. Acceptance of Seller's products shall in all events constitute such assent.

2. Payment: Payment shall be made by Buyer net 30 days from the date of delivery of the items purchased hereunder. Amounts not timely paid shall bear interest at the maximum rate permitted by law for each month or portion thereof that the Buyer is late in making payment. Any claims by Buyer for omissions or shortages in a shipment shall be waived unless Seller receives notice thereof within 30 days after Buyer's receipt of the shipment.

3. Delivery: Unless otherwise provided on the face hereof, delivery shall be made F.O.B. Seller's plant. Regardless of the method of delivery, however, risk of loss shall pass to Buyer upon Seller's delivery to a carrier. Any delivery dates shown are approximate only and Seller shall have no liability for any delays in delivery.

4. Warranty: Seller warrants that the items sold hereunder shall be free from defects in material or workmanship for a period of 18 months from date of shipment from the Company. **THIS WARRANTY COMPRISES THE SOLE AND ENTIRE WARRANTY PERTAINING TO ITEMS PROVIDED HEREUNDER. SELLER MAKES NO OTHER WARRANTY, GUARANTEE, OR REPRESENTATION OF ANY KIND WHATSOEVER. ALL OTHER WARRANTIES, INCLUDING BUT NOT LIMITED TO, MERCHANTABILITY AND FITNESS FOR PURPOSE, WHETHER EXPRESS, IMPLIED, OR ARISING BY OPERATION OF LAW, TRADE USAGE, OR COURSE OF DEALING ARE HEREBY DISCLAIMED.**

NOTWITHSTANDING THE FOREGOING, THERE ARE NO WARRANTIES WHATSOEVER ON ITEMS BUILT OR ACQUIRED WHOLLY OR PARTIALLY, TO BUYER'S DESIGN OR SPECIFICATIONS.

5. Limitation of Remedy: SELLER'S LIABILITY ARISING FROM OR IN ANY WAY CONNECTED WITH THE ITEMS SOLD OR THIS CONTRACT SHALL BE LIMITED EXCLUSIVELY TO REPAIR OR REPLACEMENT OF THE ITEMS SOLD OR REFUND OF THE PURCHASE PRICE PAID BY BUYER, AT SELLER'S SOLE OPTION. IN NO EVENT SHALL SELLER BE LIABLE FOR ANY INCIDENTAL, CONSEQUENTIAL OR SPECIAL DAMAGES OF ANY KIND OR NATURE WHATSOEVER, INCLUDING BUT NOT LIMITED TO LOST PROFITS ARISING FROM OR IN ANY WAY CONNECTED WITH THIS AGREEMENT OR ITEMS SOLD HEREUNDER, WHETHER ALLEGED TO ARISE FROM BREACH OF CONTRACT, EXPRESS OR IMPLIED WARRANTY, OR IN TORT, INCLUDING WITHOUT LIMITATION, NEGLIGENCE, FAILURE TO WARN OR STRICT LIABILITY.

6. Changes, Reschedules and Cancellations: Buyer may request to modify the designs or specifications for the items sold hereunder as well as the quantities and delivery dates thereof, or may request to cancel all or part of this order, however, no such requested modification or cancellation shall become part of the contract between Buyer and Seller unless accepted by Seller in a written amendment to this Agreement. Acceptance of any such requested modification or cancellation shall be at Seller's discretion, and shall be upon such terms and conditions as Seller may require.

7. Special Tooling: A tooling charge may be imposed for any special tooling, including without limitations, dies, fixtures, molds and patterns, acquired to manufacture items sold pursuant to this contract. Such special tooling shall be and remain Seller's property notwithstanding payment of any charges by Buyer. In no event will Buyer acquire any interest in apparatus belonging to Seller which is utilized in the manufacture of the items sold hereunder, even if such apparatus has been specially converted or adapted for such manufacture and notwithstanding any charges paid by Buyer. Unless otherwise agreed, Seller shall have the right to alter, discard or otherwise dispose of any special tooling or other property in its sole discretion at any time.

8. Buyer's Property: Any designs, tools, patterns, materials, drawings, confidential information or equipment furnished by Buyer, or any other items which become Buyer's property, may be considered obsolete and may be destroyed by Seller after two (2) consecutive years have elapsed without Buyer placing an order for the items which are manufactured using such property. Seller shall not be responsible for any loss or damage to such property while it is in Seller's possession or control.

9. Taxes: Unless otherwise indicated on the face hereof, all prices and charges are exclusive of excise, sales, use, property, occupational or like taxes which may be imposed by any taxing authority upon the manufacture, sale or delivery of the items sold hereunder. If any such taxes must be paid by Seller or if Seller is liable for the collection of such tax, the amount thereof shall be in addition to the amounts for the items sold. Buyer agrees to pay all such taxes or to reimburse Seller therefore upon receipt of its invoice. If Buyer claims exemption from any sales, use or other tax imposed by any taxing authority, Buyer shall save Seller harmless from and against any such tax, together with any interest or penalties thereon which may be assessed if the items are held to be taxable.

10. Indemnity For Infringement of Intellectual Property Rights: Seller shall have no liability for infringement of any patents, trademarks, copyrights, trade dress, trade secrets or similar rights except as provided in this Part 10. Seller will defend and indemnify Buyer against allegations of infringement of U.S. patents, U.S. trademarks, copyrights, trade dress and trade secrets (hereinafter "Intellectual Property Rights"). Seller will defend at its expense and will pay the cost of any settlement or damages awarded in an action brought against Buyer based on an allegation that an item sold pursuant to this contract infringes the Intellectual Property Rights of a third party. Seller's obligation to defend and indemnify Buyer is contingent on Buyer notifying Seller within ten (10) days after Buyer becomes aware of such allegations of infringement, and Seller having sole control over the defense of any allegations or actions including all negotiations for settlement or compromise. If an item sold hereunder is subject to a claim that it infringes the Intellectual Property Rights of a third party, Seller may, at its sole expense and option, procure for Buyer the right to continue using said item, replace or modify said item so as to make it noninfringing, or offer to accept return of said item and return the purchase price less a reasonable allowance for depreciation. Notwithstanding the foregoing, Seller shall have no liability for claims of infringement based on information provided by Buyer, or directed to items delivered hereunder for which the designs are specified in whole or part by Buyer, or infringements resulting from the modification, combination or use in a system of any item sold hereunder. The foregoing provisions of this Part 10 shall constitute Seller's sole and exclusive liability and Buyer's sole and exclusive remedy for infringement of Intellectual Property Rights.

If a claim is based on information provided by Buyer or if the design for an item delivered hereunder is specified in whole or in part by Buyer, Buyer shall defend and indemnify Seller for all costs, expenses or judgments resulting from any claim that such item infringes any patent, trademark, copyright, trade dress, trade secret or any similar right.

11. Force Majeure: Seller does not assume the risk of and shall not be liable for delay or failure to perform any of Seller's obligations by reason of circumstances beyond the reasonable control of Seller (hereinafter "Events of Force Majeure"). Events of Force Majeure shall include without limitation, accidents, acts of God, strikes or labor disputes, acts, laws, rules or regulations of any government or government agency, fires, floods, delays or failures in delivery of carriers or suppliers, shortages of materials and any other cause beyond Seller's control.

12. Entire Agreement/Governing Law: The terms and conditions set forth herein, together with any amendments, modifications and any different terms or conditions expressly accepted by Seller in writing, shall constitute the entire Agreement concerning the items sold, and there are no oral or other representations or agreements which pertain thereto. This Agreement shall be governed in all respects by the law of the State of Ohio. No actions arising out of sale of the items sold hereunder or this Agreement may be brought by either party more than two (2) years after the cause of action accrues.

ATLAS
CYLINDERS

500 S. Wolf Rd.
Des Plaines, IL 60016 USA
Tel.: (847) 298-2400
Fax.: (800) 892-1008
www.AtlasCylinders.com • atlasclmktg@parker.com